

D

D

C

C

B

B

A

A

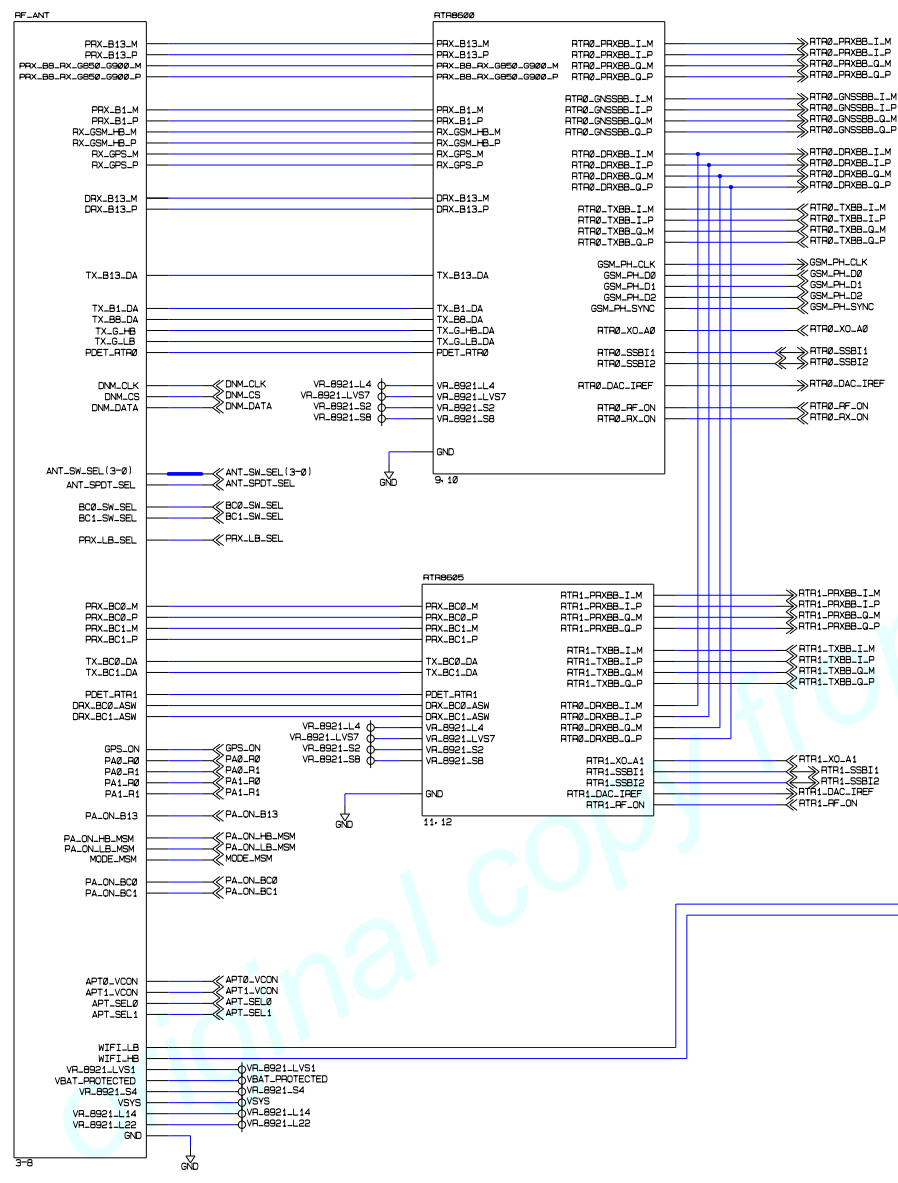

RF SECTIONS ARE DIFFERENT IN THE SPRINT AND VERIZON VERSIONS

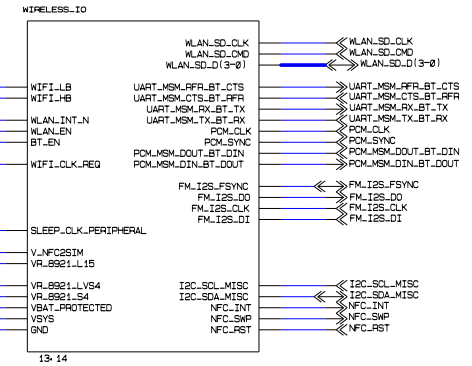

RESEARCH IN MOTION CONFIDENTIAL

HIERARCHICAL BLOCK MAIN	COPYRIGHT 2012 RESEARCH IN MOTION LIMITED 295 PHILIP ST. WATERLOO, ONTARIO CANADA
DRAWN BY A. Shafique	PHONE (519) 888-7465. FAX (519) 888-6986
R&D CHECK Ottawa CDMA Team	TITLE R069 VERIZON
MFG CHECK mfqch	uses PCB-44884-010
EDITED BY ashafique	SIZE DRAWING No. SCH-44885-010
LAST EDIT: 2013/01/08 08:29:06	REV 2 SHEET 1 of 34

D

D

C

C

B

B

A

A

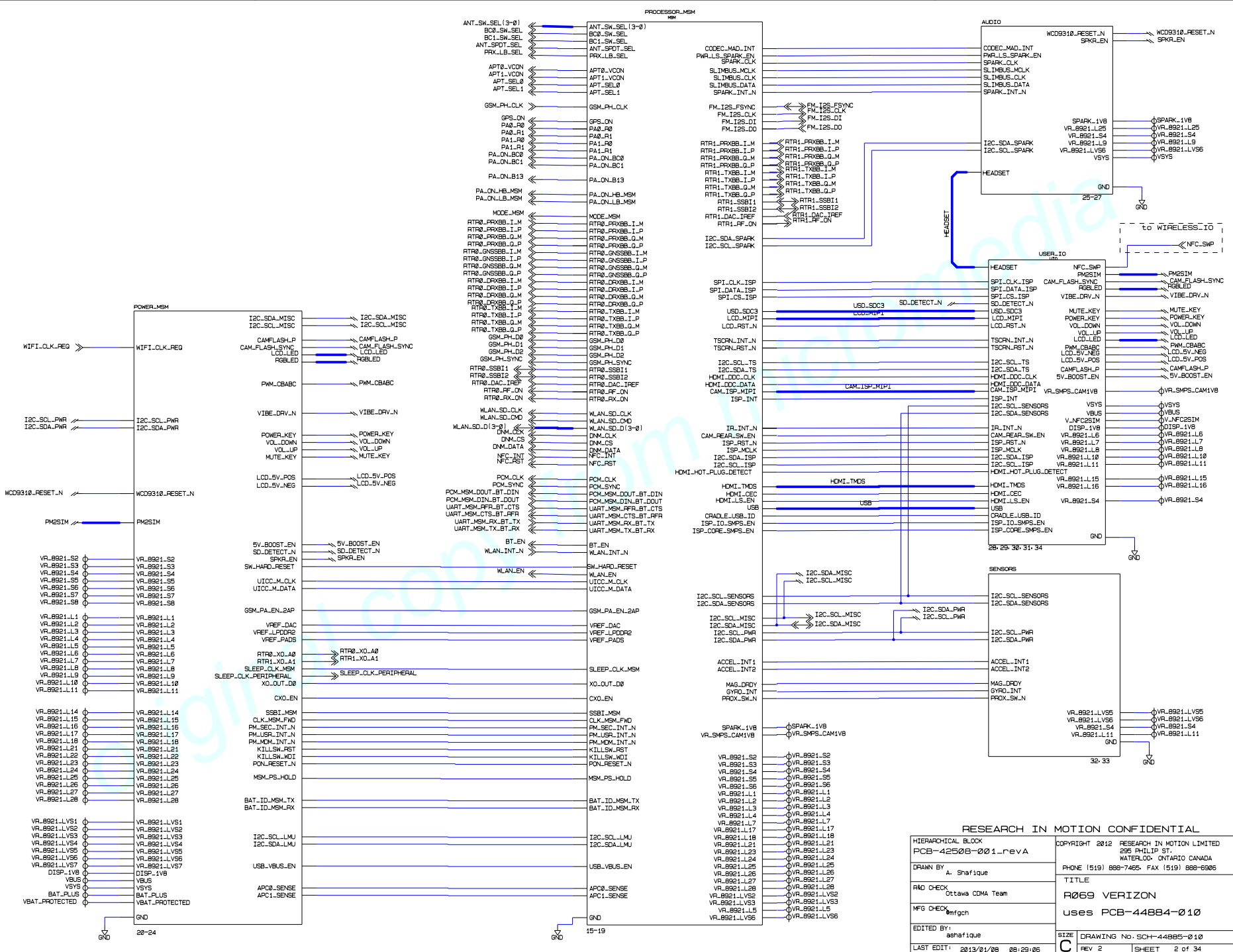

<p>RESEARCH IN MOTION CONFIDENTIAL</p> <p>HIERARCHICAL BLOCK PCB-42508-001-reva</p> <p>DRAWN BY A. Shafique</p> <p>RAD CHECK Ottawa CDMA Team</p> <p>MFG CHECK emgch</p> <p>EDITED BY: ashafique</p> <p>LAST EDIT: 2013/01/08 08:29:05</p>		<p>COPYRIGHT 2012 RESEARCH IN MOTION LIMITED 295 PHILIP ST. WATERLOO, ONTARIO CANADA PHONE (519) 886-7465, FAX (519) 886-6986</p> <p>TITLE R069 VERIZON uses PCB-44884-010</p> <p>SIZE DRAWING No. SCH-44885-010</p> <p>REV 2 SHEET 2 of 34</p>	
--	--	---	--

ANT 4 (Bottom)

Place R328, R334 and R311 close to FL302; R323 and R336 close to FL304

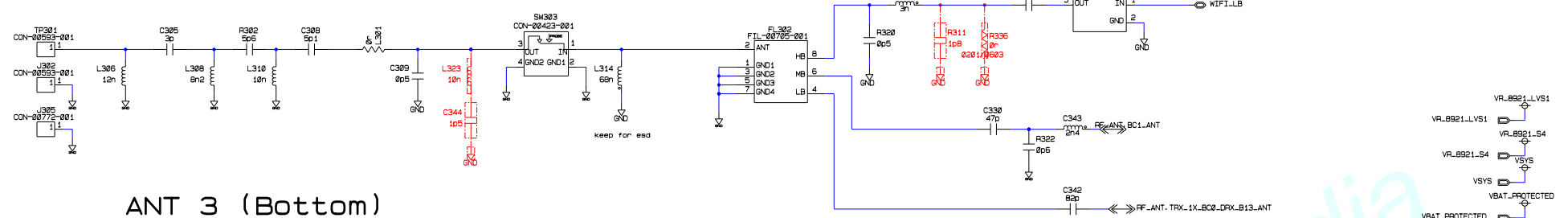

ANT 3 (Bottom)

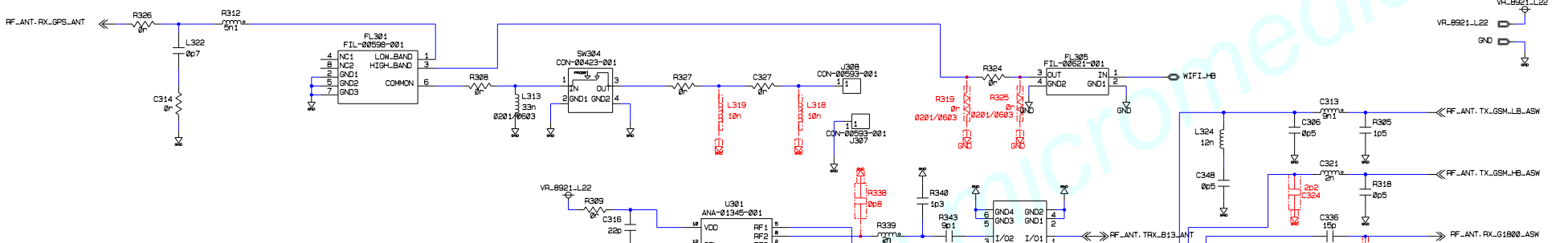

ANT 1 (TOP)

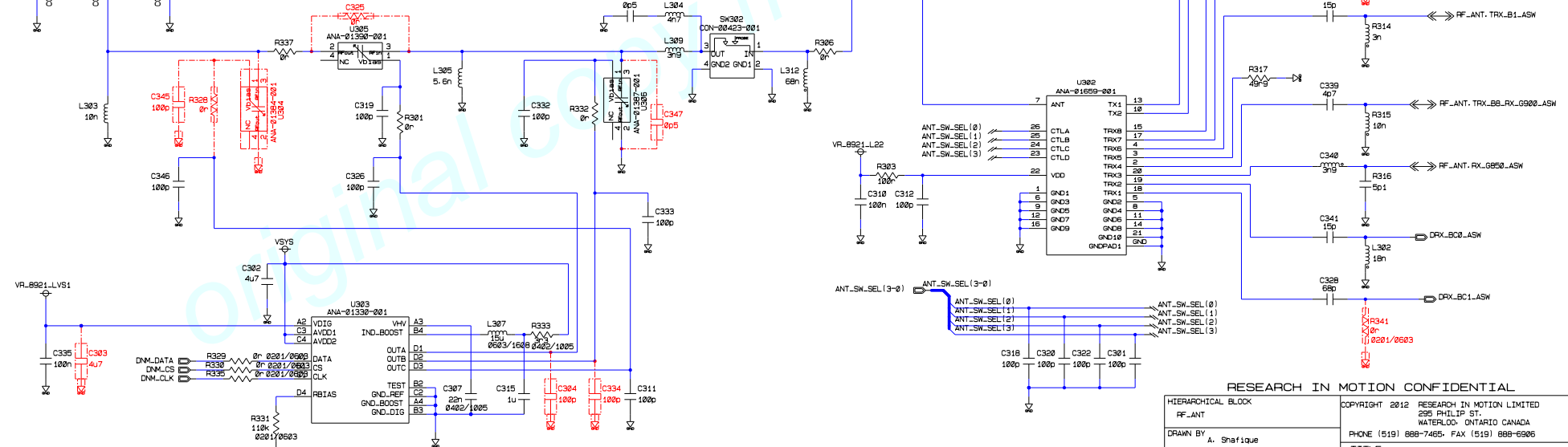

ANT 2 (Bottom)

no B4 in the first build



RESEARCH IN MOTION CONFIDENTIAL	
HIERARCHICAL BLOCK RF_ANT	COPYRIGHT 2012 RESEARCH IN MOTION LIMITED 295 PHILIP ST. WATERLOO, ONTARIO CANADA
DRAWN BY A. Shafique	PHONE (519) 888-7465, FAX (519) 888-6906
RMD CHECK Ottawa CDMA Team	TITLE R069 VERIZON
MFG CHECK mfgch	uses PCB-44884-010
EDITED BY: ashafique	SIZE DRAWING No. SCH-44885-010
LAST EDIT: 2013/01/08 08:29:07	REV 2 SHEET 3 of 34

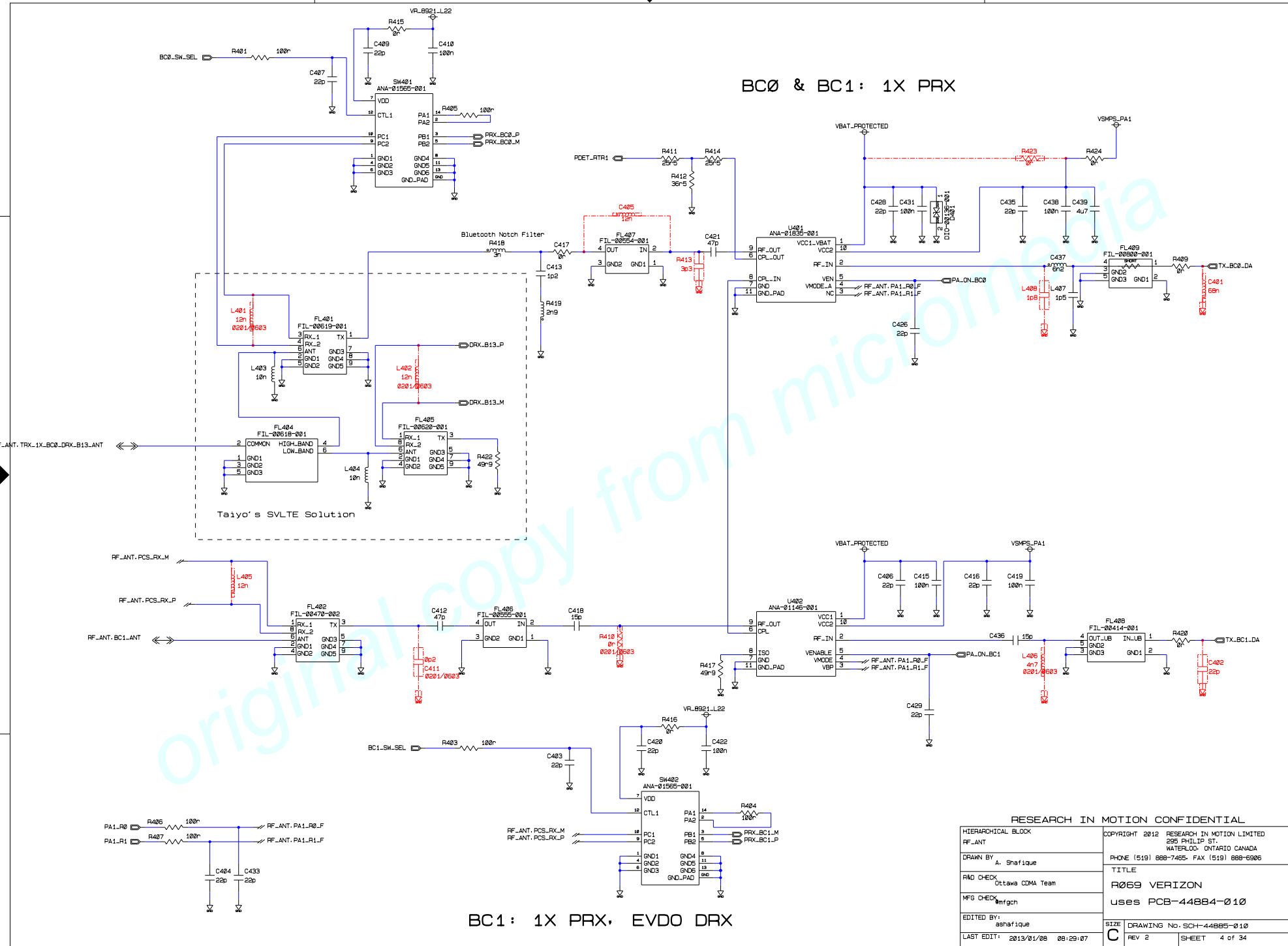

BC0 & BC1: 1X PRX

BC1: 1X PRX, EVDO DRX

RESEARCH IN MOTION CONFIDENTIAL	
HIERARCHICAL BLOCK RF_ANT	COPYRIGHT 2012 RESEARCH IN MOTION LIMITED 295 PHILIP ST. WATERLOO, ONTARIO CANADA
DRAWN BY A. Shafique	PHONE (519) 886-7465- FAX (519) 886-6966
RFMD CHECK Ottawa CDMA Team	TITLE R069 VERIZON uses PCB-44884-010
MFG CHECK Infogch	SIZE DRAWING NO. SCH-44885-010
EDITED BY: ashaf1que	C REV 2 SHEET 4 of 34
LAST EDIT: 2013/01/08 09:29:07	

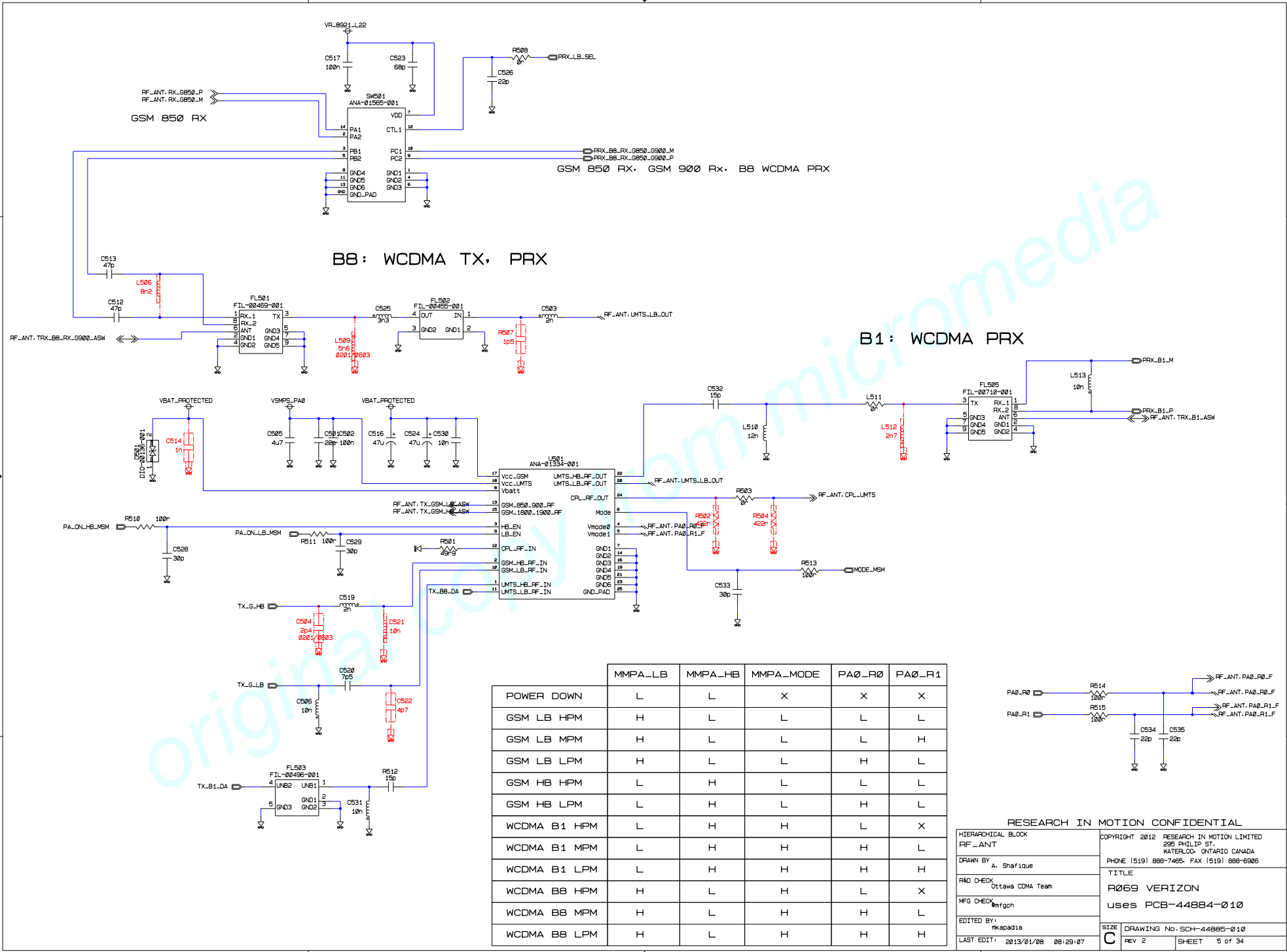

	MMPA_LL	MMPA_HB	MMPA_MODE	PA0_R0	PA0_R1
POWER DOWN	L	L	X	X	X
GSM LB HPM	H	L	L	L	L
GSM LB MPM	H	L	L	L	H
GSM LB LPM	H	L	L	H	L
GSM HB HPM	L	H	L	L	L
GSM HB LPM	L	H	L	H	L
WCDMA B1 HPM	L	H	H	L	X
WCDMA B1 MPM	L	H	H	H	L
WCDMA B1 LPM	L	H	H	H	H
WCDMA BB HPM	H	L	H	L	X
WCDMA BB MPM	H	L	H	H	L
WCDMA BB LPM	H	L	H	H	H

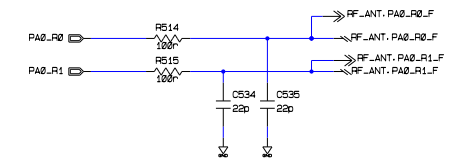

RESEARCH IN MOTION CONFIDENTIAL

HIERARCHICAL BLOCK RF_ANT	COPYRIGHT 2012 RESEARCH IN MOTION LIMITED 295 PHILIP ST. WATERLOO, ONTARIO CANADA PHONE (519) 889-7465, FAX (519) 889-6986
DRAWN BY A. Shafique	TITLE R069 VERIZON uses PCB-44884-010
RAD CHECK Ottawa CDMA Team	SIZE DRAWING No. SCH-44885-010
MFG CHECK mfqch	REV 2 SHEET 5 of 34
EDITED BY mkapadja	
LAST EDIT: 2013/01/08 08:29:07	

GSM850 RX

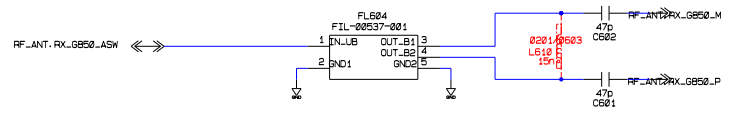

B13: LTE TX, PRX

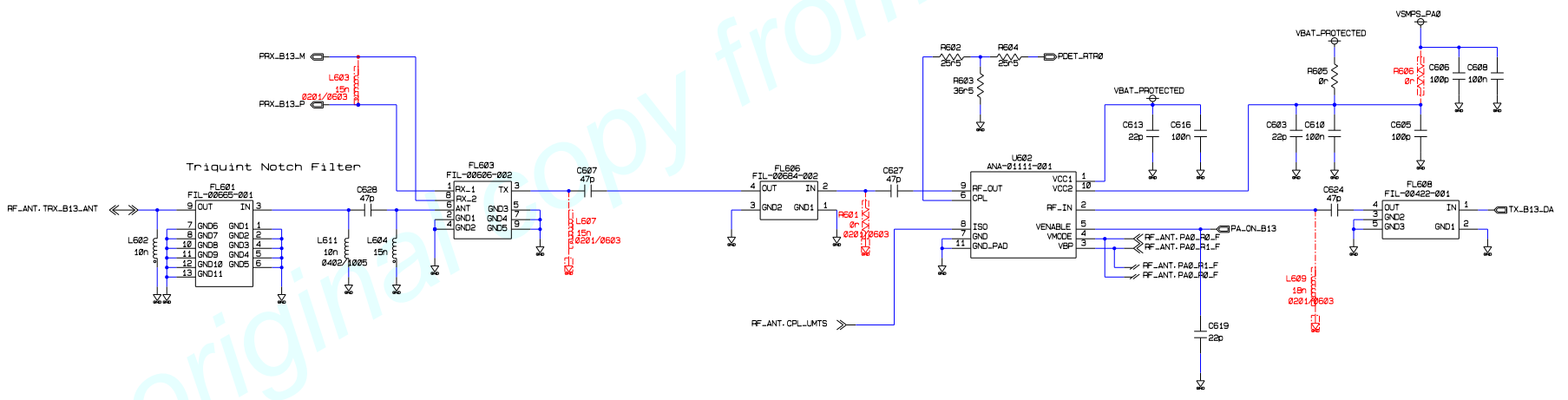

RESEARCH IN MOTION CONFIDENTIAL

HIERARCHICAL BLOCK RF_ANT	COPYRIGHT 2012 RESEARCH IN MOTION LIMITED 295 PHILLIP ST. WATERLOO, ONTARIO CANADA PHONE (519) 888-7465, FAX (519) 888-6986
DRAWN BY A. Shafique	TITLE R069 VERIZON uses PCB-44884-010
R&D CHECK Ottawa CDMA Team	SIZE DRAWING No. SCH-44885-010
MFG CHECK mfqch	REV 2 SHEET 6 of 34
EDITED BY ashafique	
LAST EDIT: 2013/01/08 08:29:07	

D

D

C

C

B

B

A

A

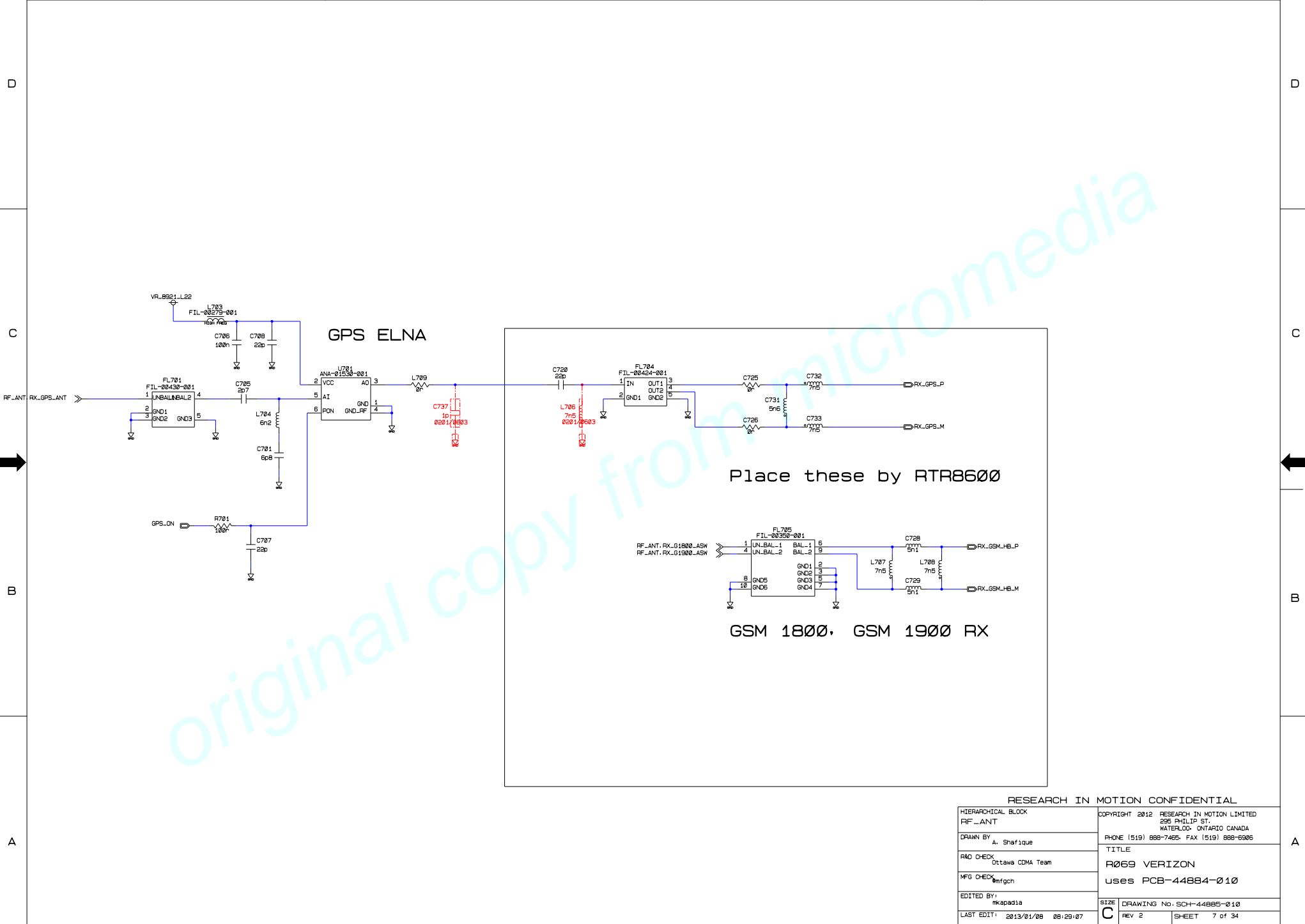

Place these by RTR8600

GSM 1800, GSM 1900 RX

RESEARCH IN MOTION CONFIDENTIAL

HIERARCHICAL BLOCK RF_ANT	COPYRIGHT 2012 RESEARCH IN MOTION LIMITED 295 PHILIP ST. WATERLOO, ONTARIO CANADA PHONE (519) 888-7465, FAX (519) 888-6986
DRAWN BY A. Shafique	TITLE R069 VERIZON uses PCB-44884-010
R&D CHECK Ottawa CDMA Team	SIZE DRAWING No. SCH-44885-010
MFG CHECK mfqch	REV 2 SHEET 7 of 34
EDITED BY mkapadia	
LAST EDIT: 2013/01/08 08:29:07	

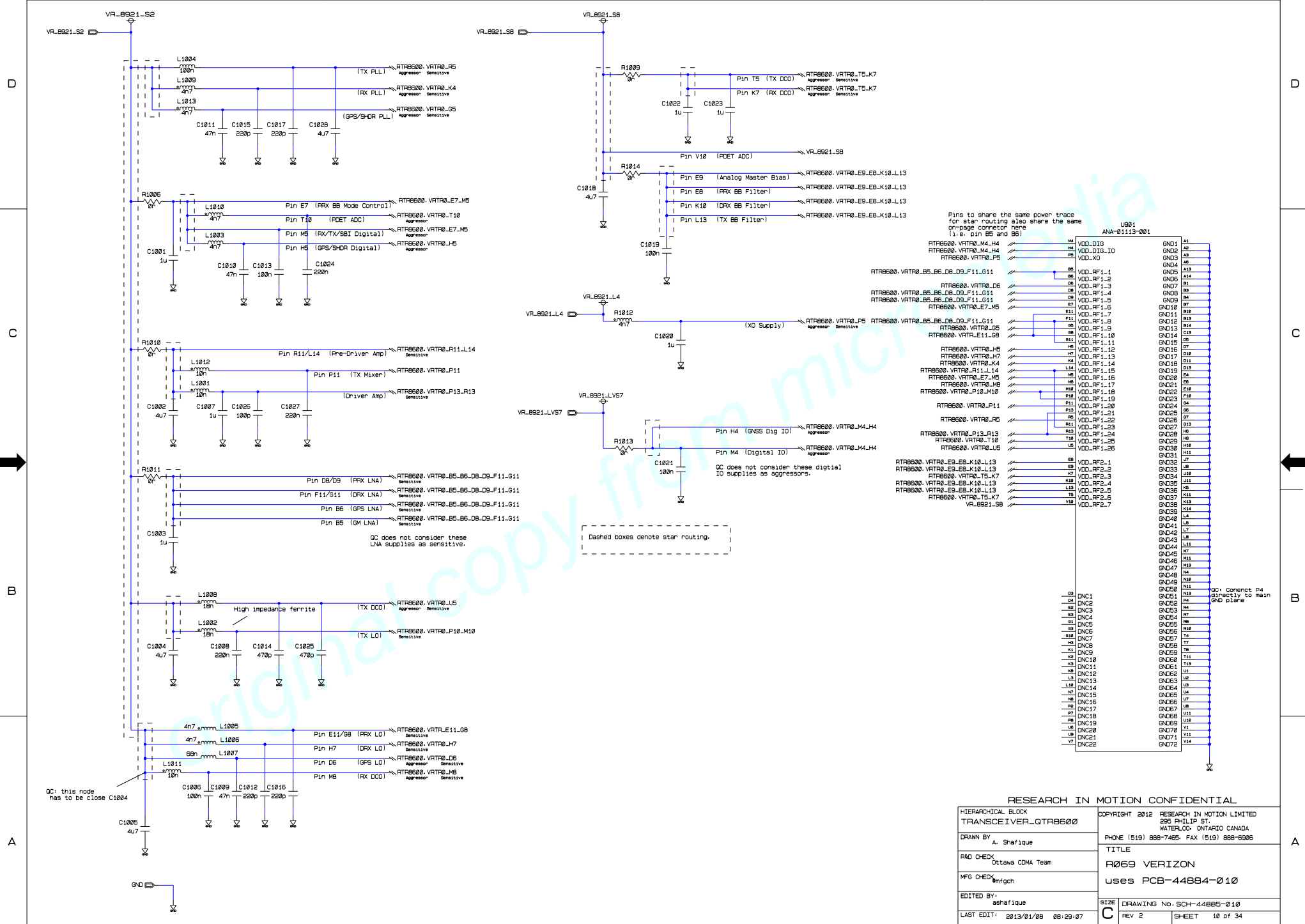

A

B

C

D

A

B

C

D

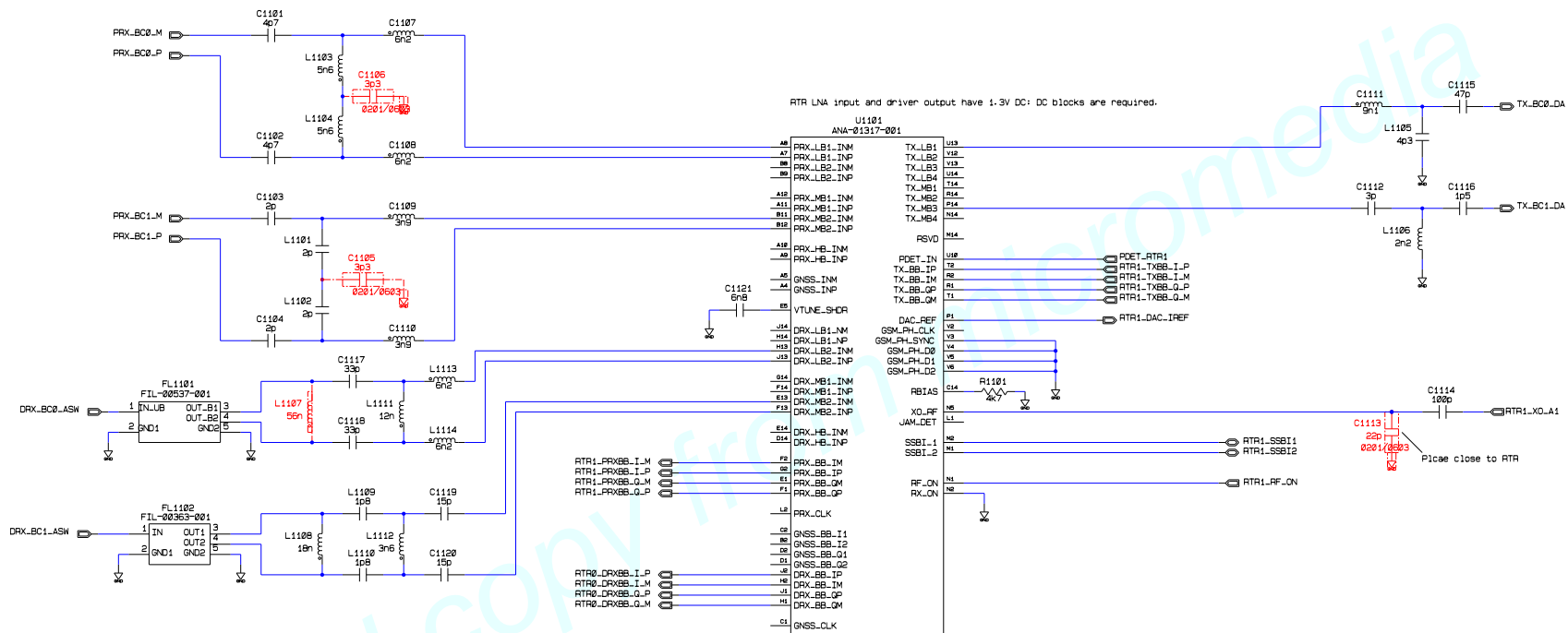

RESEARCH IN MOTION CONFIDENTIAL	
HIERARCHICAL BLOCK TRANSCIVER_RTR0605	COPYRIGHT 2012 RESEARCH IN MOTION LIMITED 295 PHILIP ST. WATERLOO, ONTARIO CANADA PHONE (519) 888-7465 FAX (519) 888-6986
DRAWN BY A. Shafiqe	TITLE R069 VERIZON uses PCB-44884-010
R&D CHECK Ottawa CDMA Team	SIZE DRAWING No. SCH-44885-010
MFG CHECK mfqch	REV 2
EDITED BY ashafiqe	SHEET 11 of 34
LAST EDIT: 2013/01/08 08:29:07	

D

C

B

A

D

C

B

A

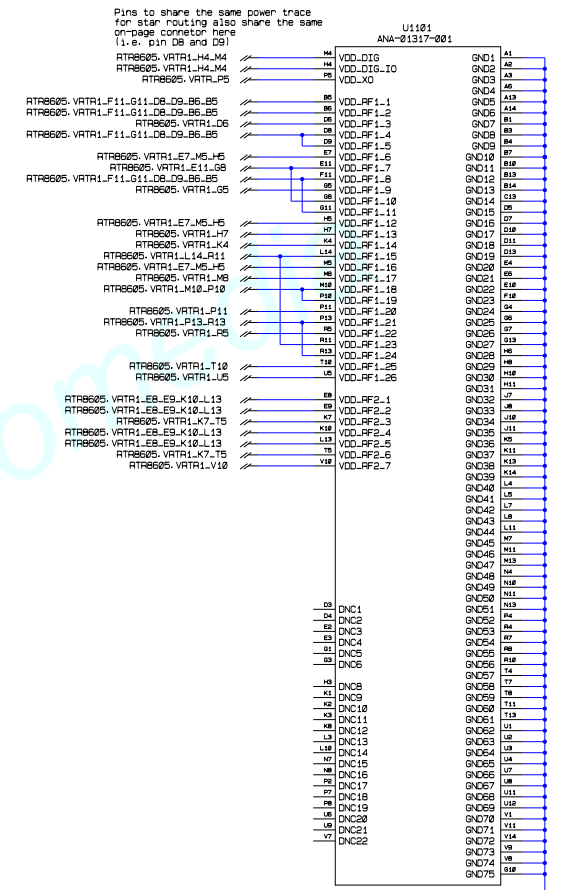
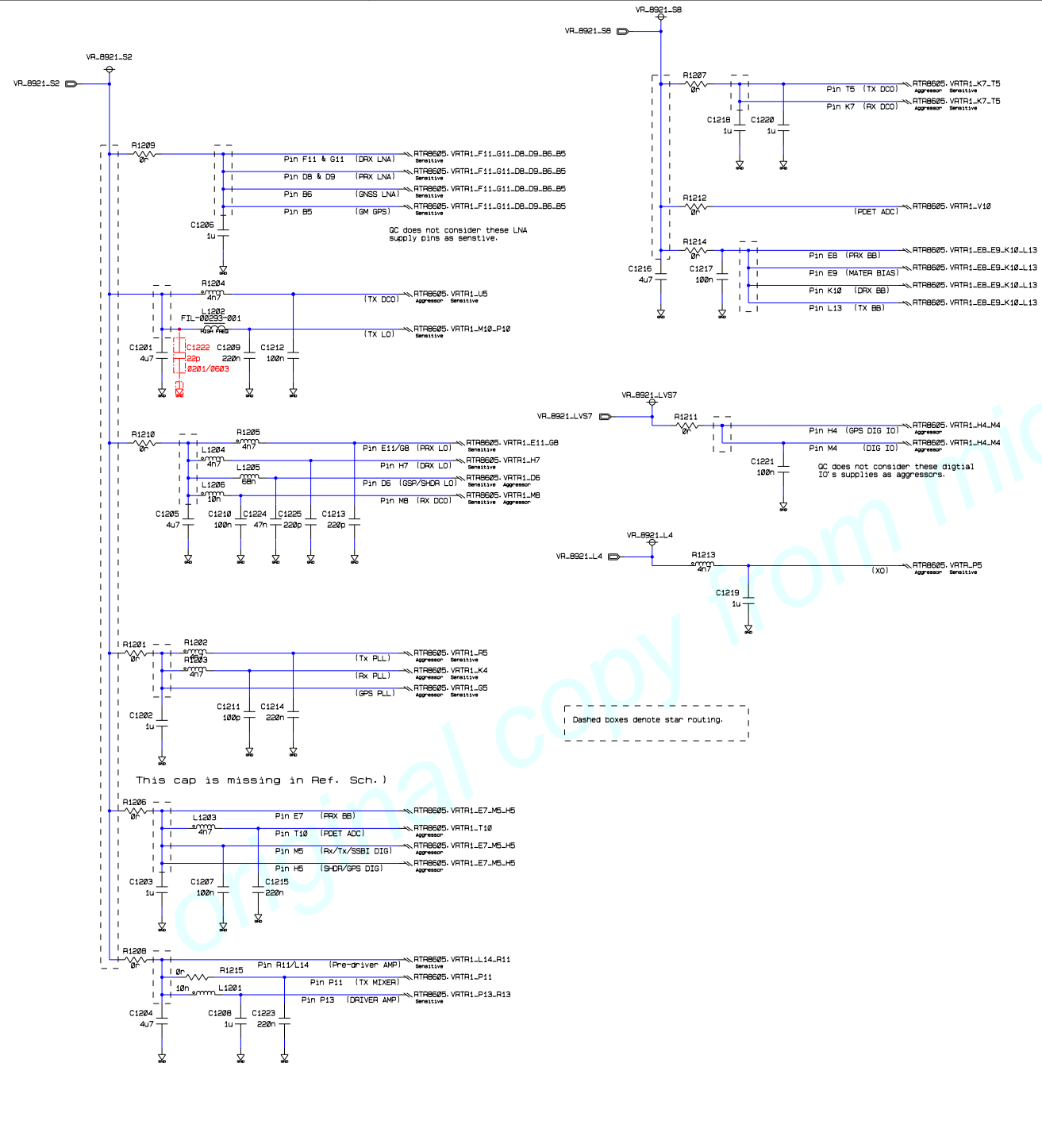

RESEARCH IN MOTION CONFIDENTIAL

HIERARCHICAL_BLOCK TRANSCIEVER_RTR8605	COPYRIGHT 2012 RESEARCH IN MOTION LIMITED 295 PHILLIP ST. WATERLOO, ONTARIO CANADA PHONE (519) 888-7465, FAX (519) 888-6986
DRAWN BY A. Shafique	TITLE R069 VERIZON
RWD CHECK Ottawa CDMA Team	uses PCB-44884-010
MFG CHECK mfqch	SIZE DRAWING No. SCH-44885-010
EDITED BY ashafique	REV 2
LAST EDIT: 2013/01/08 08:29:07	SHEET 12 of 34

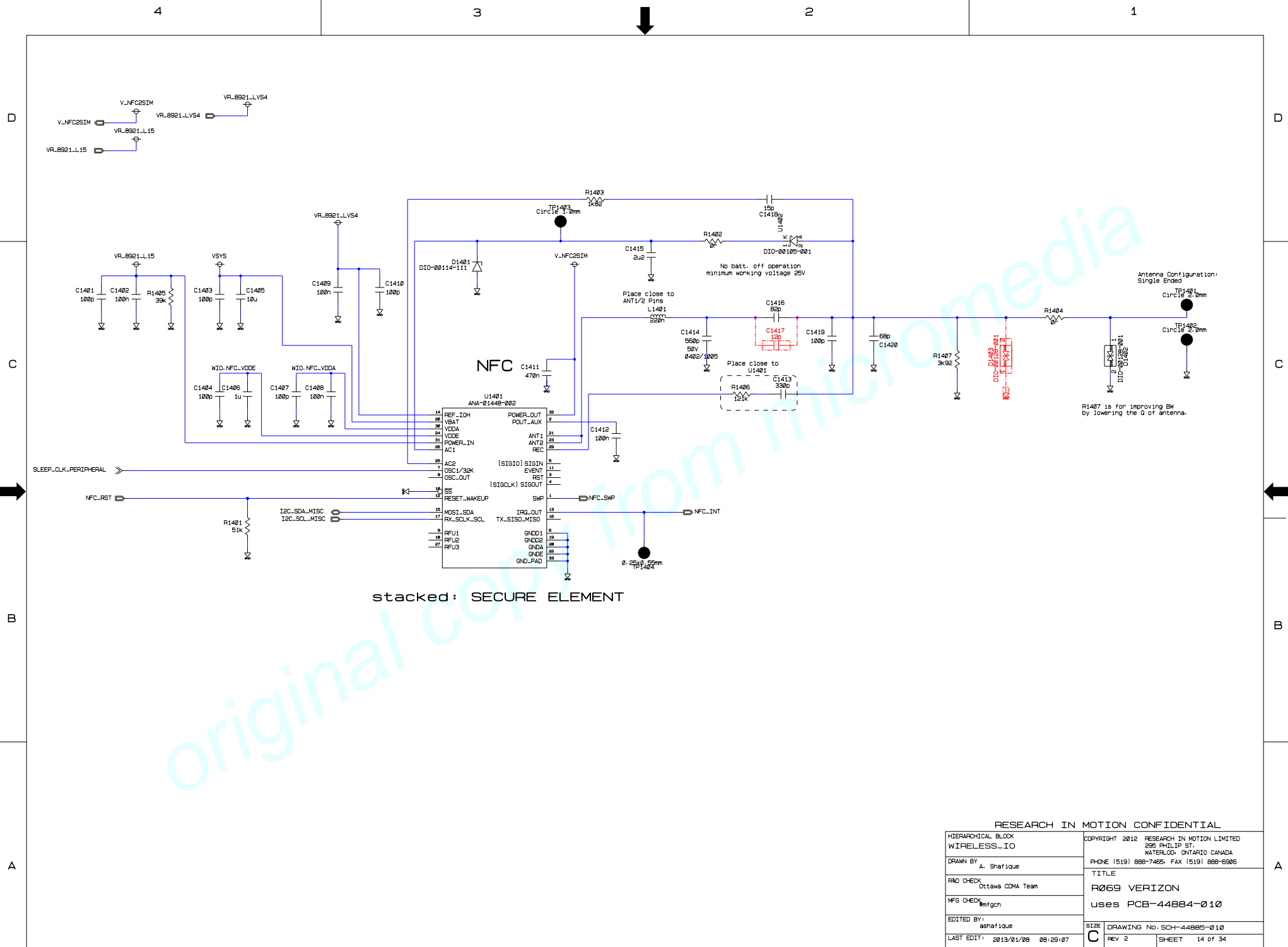

stacked: SECURE ELEMENT

RESEARCH IN MOTION CONFIDENTIAL

HIERARCHICAL BLOCK WIRELESS_IO	COPYRIGHT 2012 RESEARCH IN MOTION LIMITED 295 PHILIP ST. WATERLOO, ONTARIO CANADA
DRAWN BY A. Shafique	PHONE (519) 888-7465 FAX (519) 888-6986
R&D CHECK Ottawa CDMA Team	TITLE R069 VERIZON
MFG CHECK mfqch	uses PCB-44884-010
EDITED BY: ashafique	SIZE DRAWING No. SCH-44885-010
LAST EDIT: 2013/01/08 08:29:07	REV 2 SHEET 14 of 34

D

D

C

C

B

B

A

A

MSM8960 GPIO

U1501
DIG-8954E-022
MSM8960-GPIO1

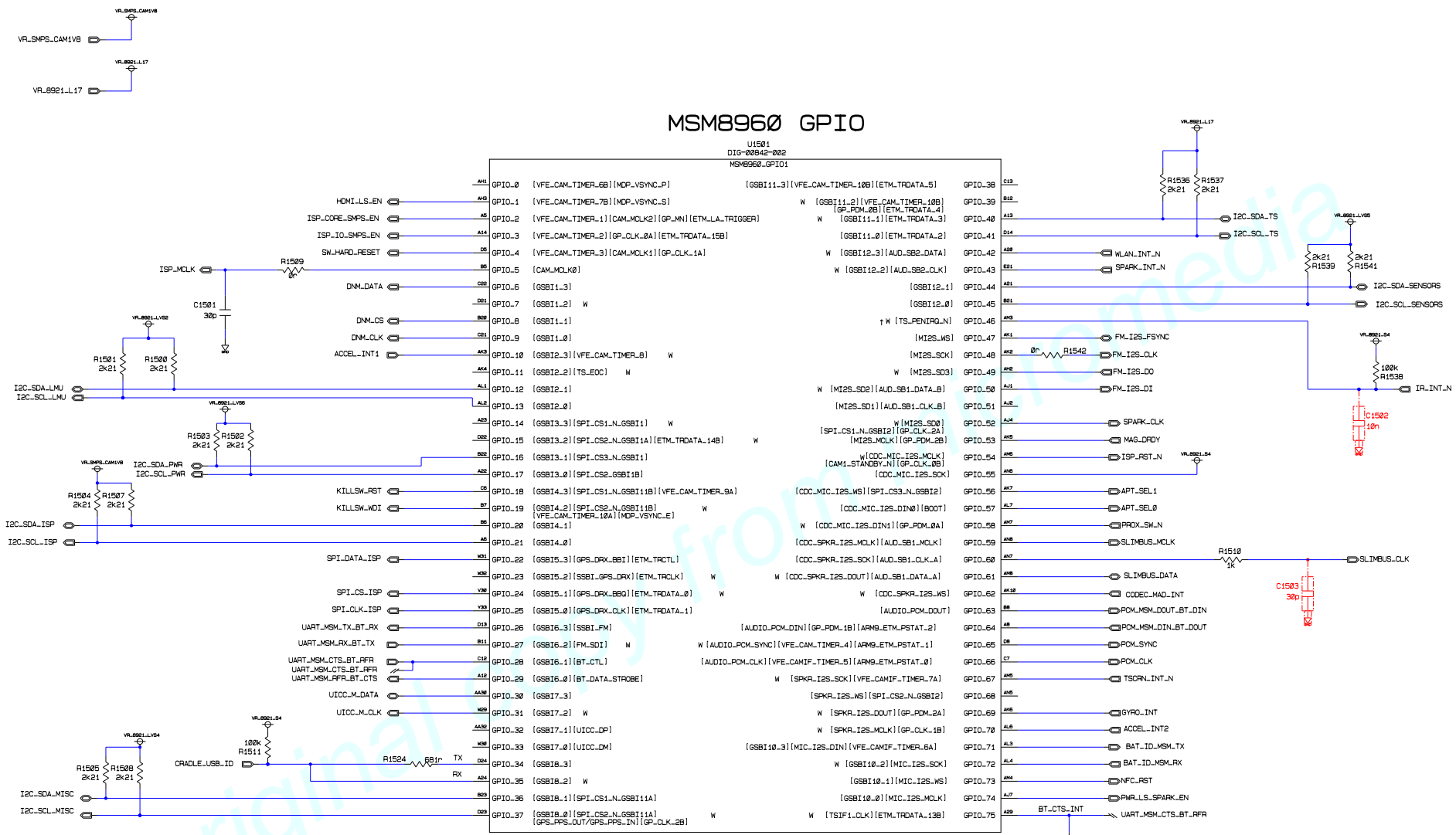

RESEARCH IN MOTION CONFIDENTIAL

HIERARCHICAL BLOCK PROCESSOR_MSM	COPYRIGHT 2012 RESEARCH IN MOTION LIMITED 295 PHILIP ST. WATERLOO, ONTARIO CANADA
DRAWN BY A. Shafique	PHONE (519) 888-7465 FAX (519) 888-6986
RWD CHECK Ottawa CDMA Team	TITLE R069 VERIZON
MFG CHECK omfgch	uses PCB-44884-010
EDITED BY ashafique	SIZE DRAWING No. SCH-44885-010
LAST EDIT: 2013/01/08 08:29:08	REV 2 SHEET 15 of 34

D

D

C

C

B

B

A

A

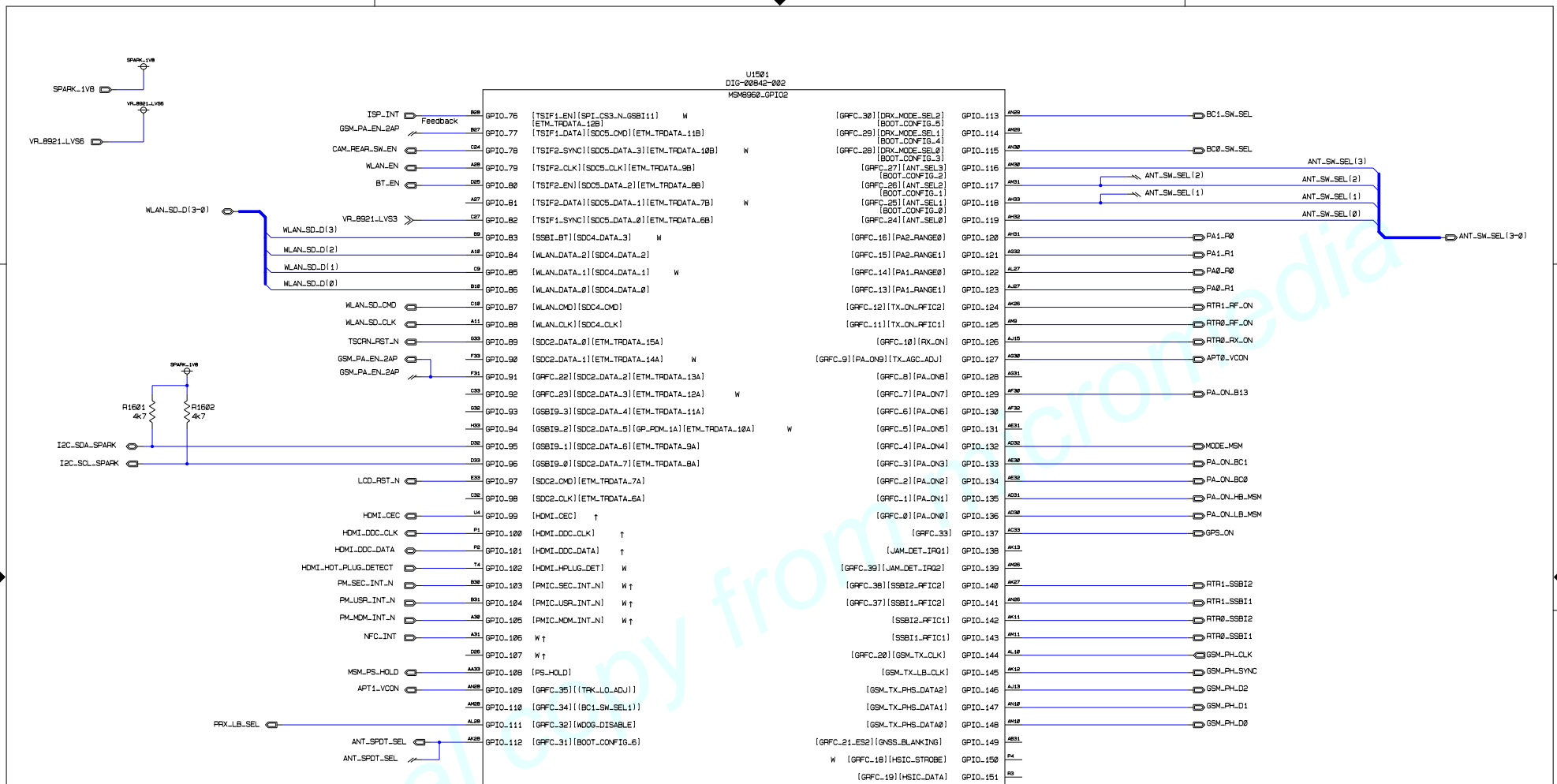

MSM8960 RF INTERFACE

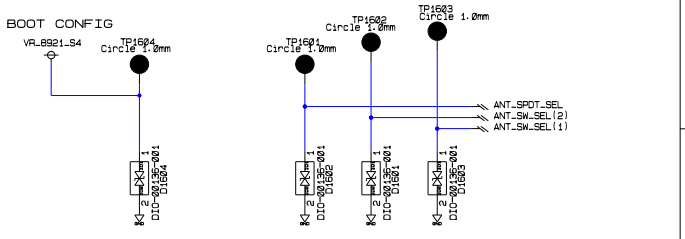
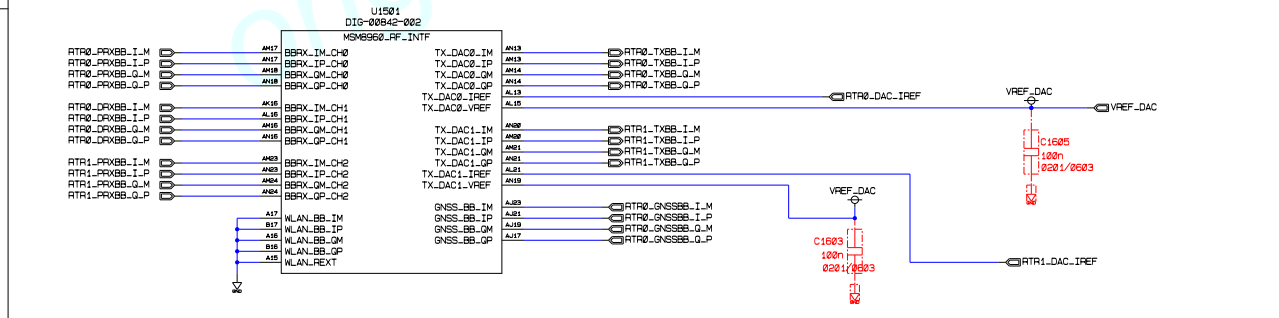

RESEARCH IN MOTION CONFIDENTIAL	
HIERARCHICAL BLOCK PROCESSOR_MSM	COPYRIGHT 2012 RESEARCH IN MOTION LIMITED 295 PHILIP ST. WATERLOO, ONTARIO CANADA
DRAWN BY: A. Shafiqe	PHONE (519) 889-7465, FAX (519) 888-6986
R&D CHECK Ottawa CDMA Team	TITLE R069 VERIZON
MFG CHECK mfgch	uses PCB-44884-010
EDITED BY: ashafiqe	SIZE DRAWING No. SCH-44885-010
LAST EDIT: 2013/01/08 08:29:08	REV 2 SHEET 16 of 34

eMMC Power

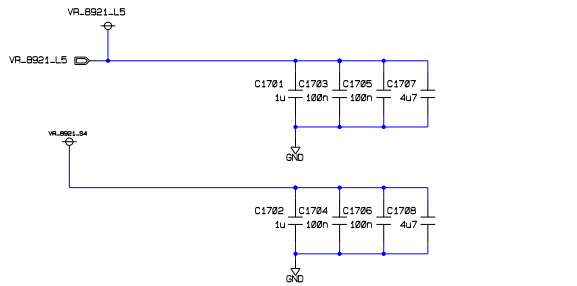

MSM8960 MEMORY INTERFACE

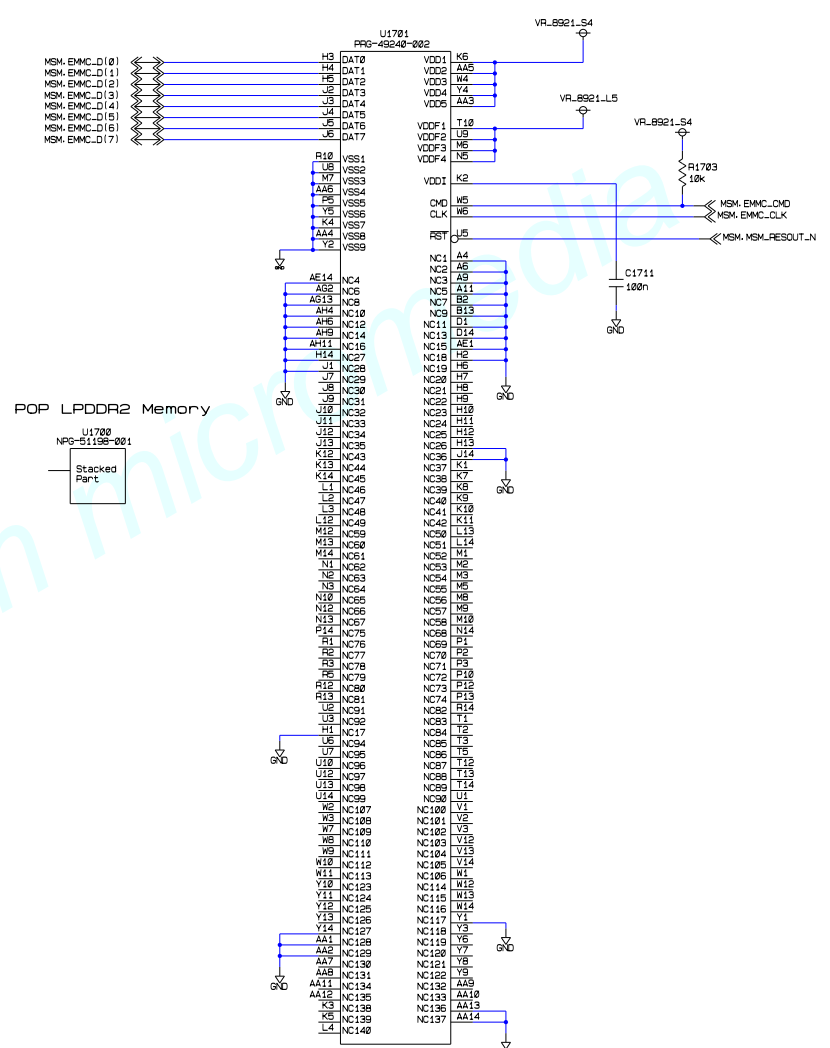

MSM8960 GND

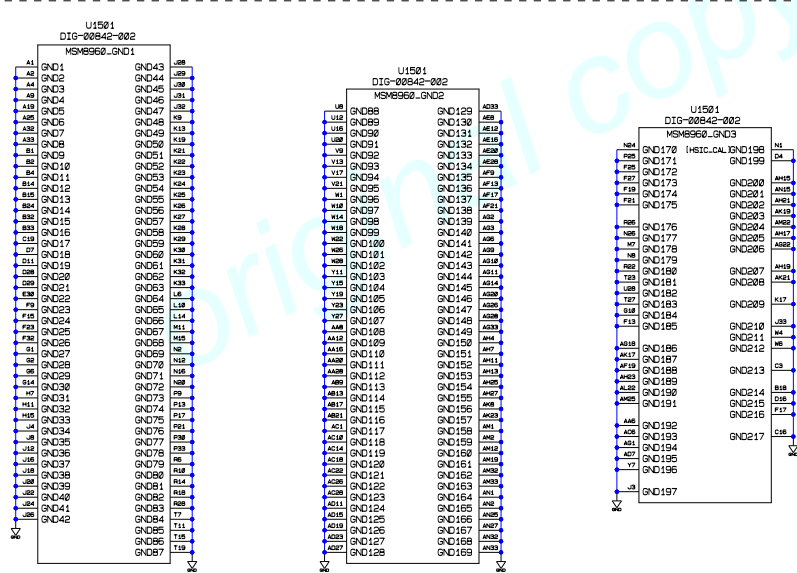

RESEARCH IN MOTION CONFIDENTIAL		
HIERARCHICAL BLOCK PROCESSOR_MSM	COPYRIGHT 2012 RESEARCH IN MOTION LIMITED 295 PHILIP ST. WATERLOO, ONTARIO CANADA	
DRAWN BY A. Shafique	PHONE (519) 886-7465. FAX (519) 886-6986	
RFD CHECK Ottawa CDMA Team	TITLE R069 VERIZON	
MFG CHECK emfgch	uses PCB-44884-010	
EDITED BY: ashafique	SIZE C	DRAWING No. SCH-44885-010
LAST EDIT: 2013/01/08 08:29:08	REV 2	SHEET 17 of 34

D

D

C

C

B

B

A

A

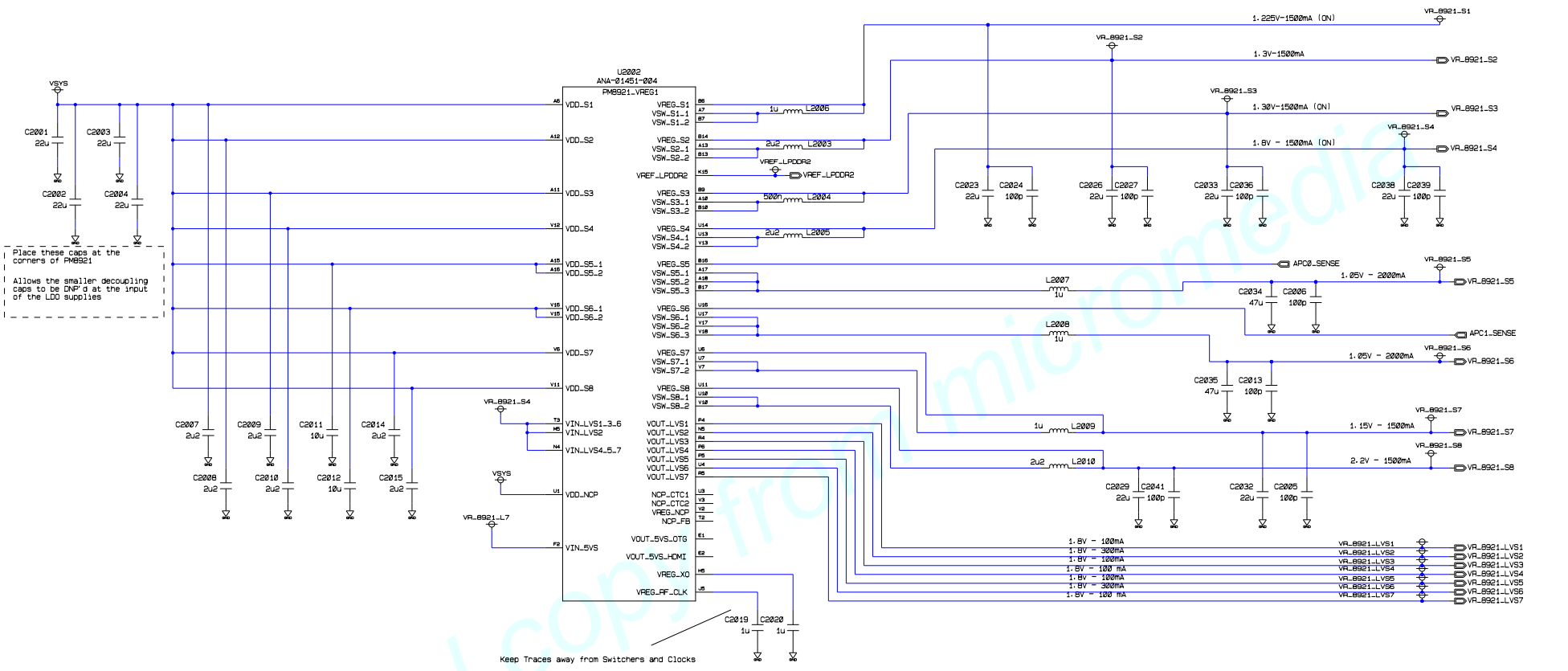

* Current ratings listed are maximums

RESEARCH IN MOTION CONFIDENTIAL

HIERARCHICAL BLOCK POWER_MSM	COPYRIGHT 2012 RESEARCH IN MOTION LIMITED 295 PHILIP ST. WATERLOO, ONTARIO CANADA
DRAWN BY A. Shafique	PHONE (519) 886-7465 FAX (519) 886-6986
R&D CHECK Ottawa CDMA Team	TITLE R069 VERIZON
MFG CHECK mfqch	uses PCB-44884-010
EDITED BY ashafique	SIZE DRAWING No. SCH-44885-010
LAST EDIT: 2013/01/08 08:29:09	REV 2 SHEET 20 of 34

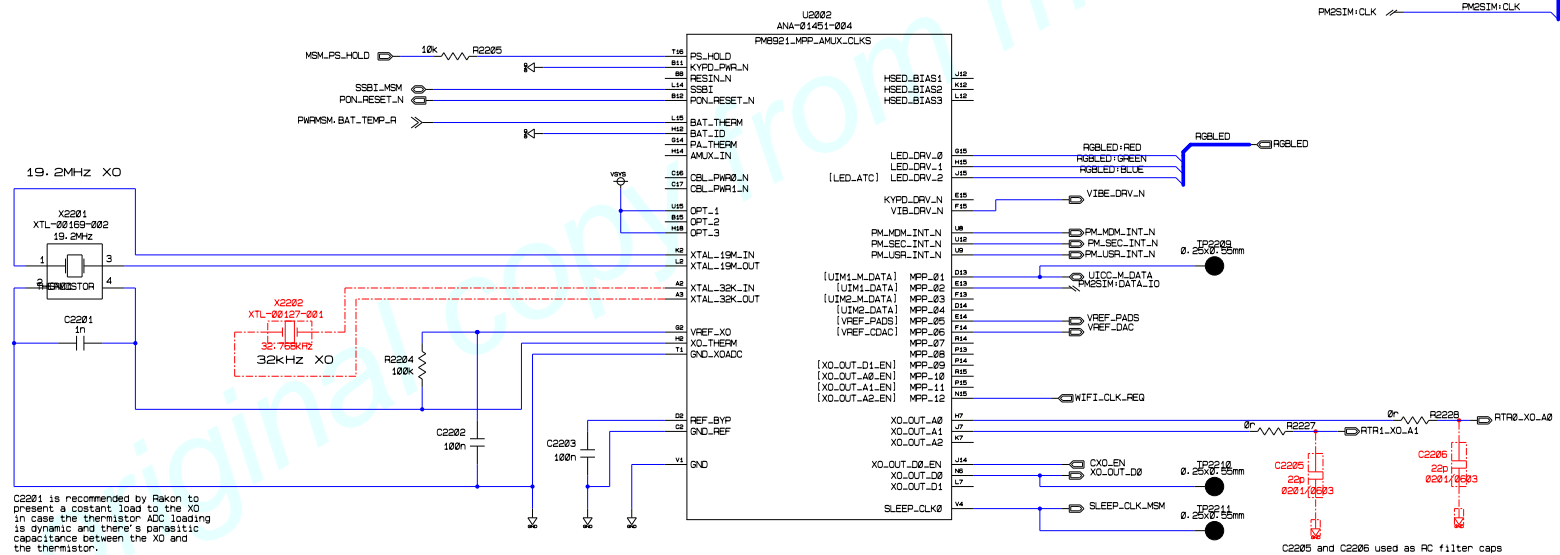
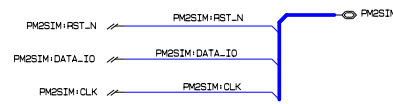
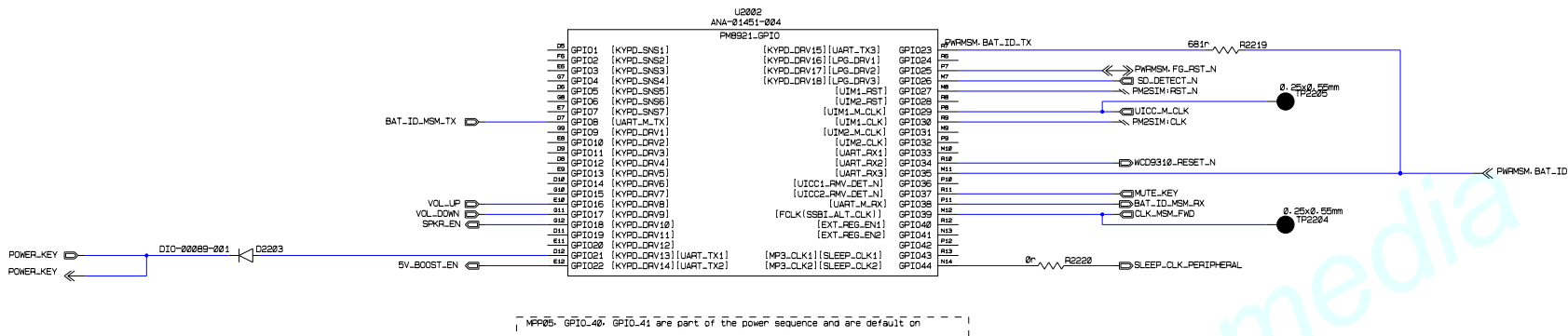

RESEARCH IN MOTION CONFIDENTIAL	
HIERARCHICAL BLOCK POWER_MSM	COPYRIGHT 2012 RESEARCH IN MOTION LIMITED 295 PHILIP ST. WATERLOO, ONTARIO CANADA PHONE (519) 886-7465 FAX (519) 886-6986
DRAWN BY A. Shafique	TITLE R069 VERIZON uses PCB-44884-010
R&D CHECK Ottawa CDMA Team	SIZE DRAWING No. SCH-44885-010
MFG CHECK mfqch	REV 2 SHEET 22 of 34
EDITED BY ashafique	
LAST EDIT: 2013/01/08 08:29:09	

Camera Flash Combination Logic

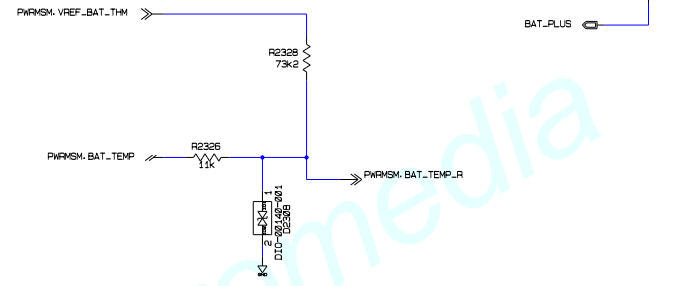
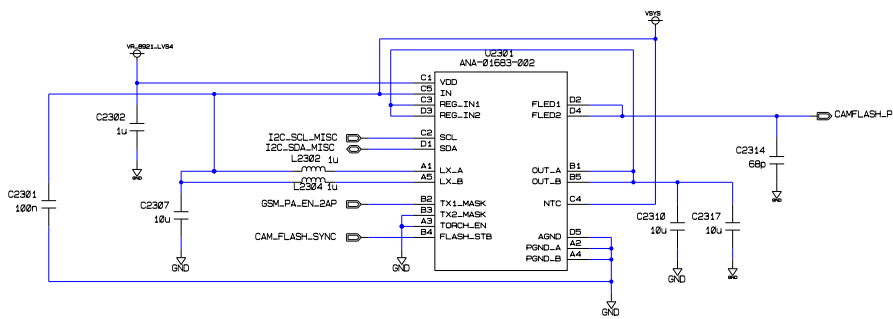

Battery

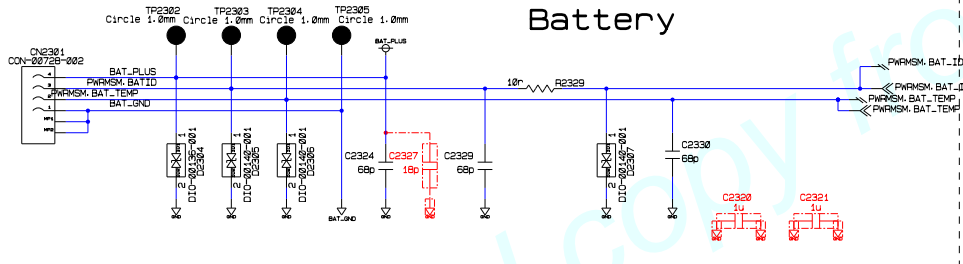

Current Sensing/Fuel Gauge

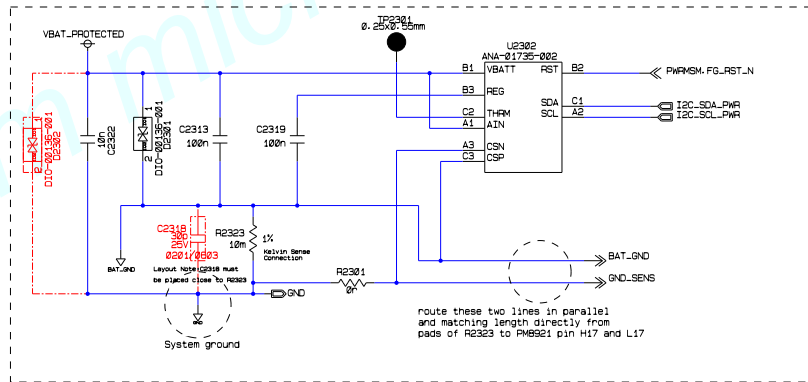

LCD Backlight and Driver Power

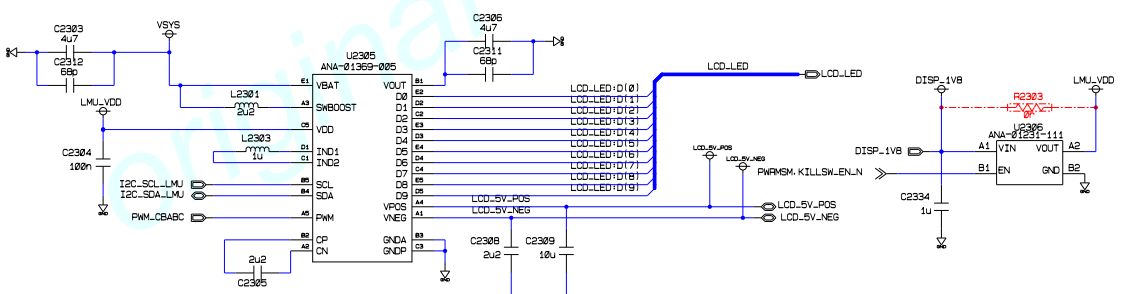

RESEARCH IN MOTION CONFIDENTIAL		
HIERARCHICAL BLOCK POWER_MSM	COPYRIGHT 2012 RESEARCH IN MOTION LIMITED 295 PHILIP ST. WATERLOO, ONTARIO CANADA	
DRAWN BY A. Shafique	PHONE (519) 886-7465 FAX (519) 886-6986	
RND CHECK Ottawa CDMA Team	TITLE R069 VERIZON	
MFG CHECK mfqch	uses PCB-44884-010	
EDITED BY ashafique	SIZE DRAWING No. SCH-44885-010	
LAST EDIT: 2013/01/08 08:29:09	C	REV 2 SHEET 23 of 34

Watchdog circuit

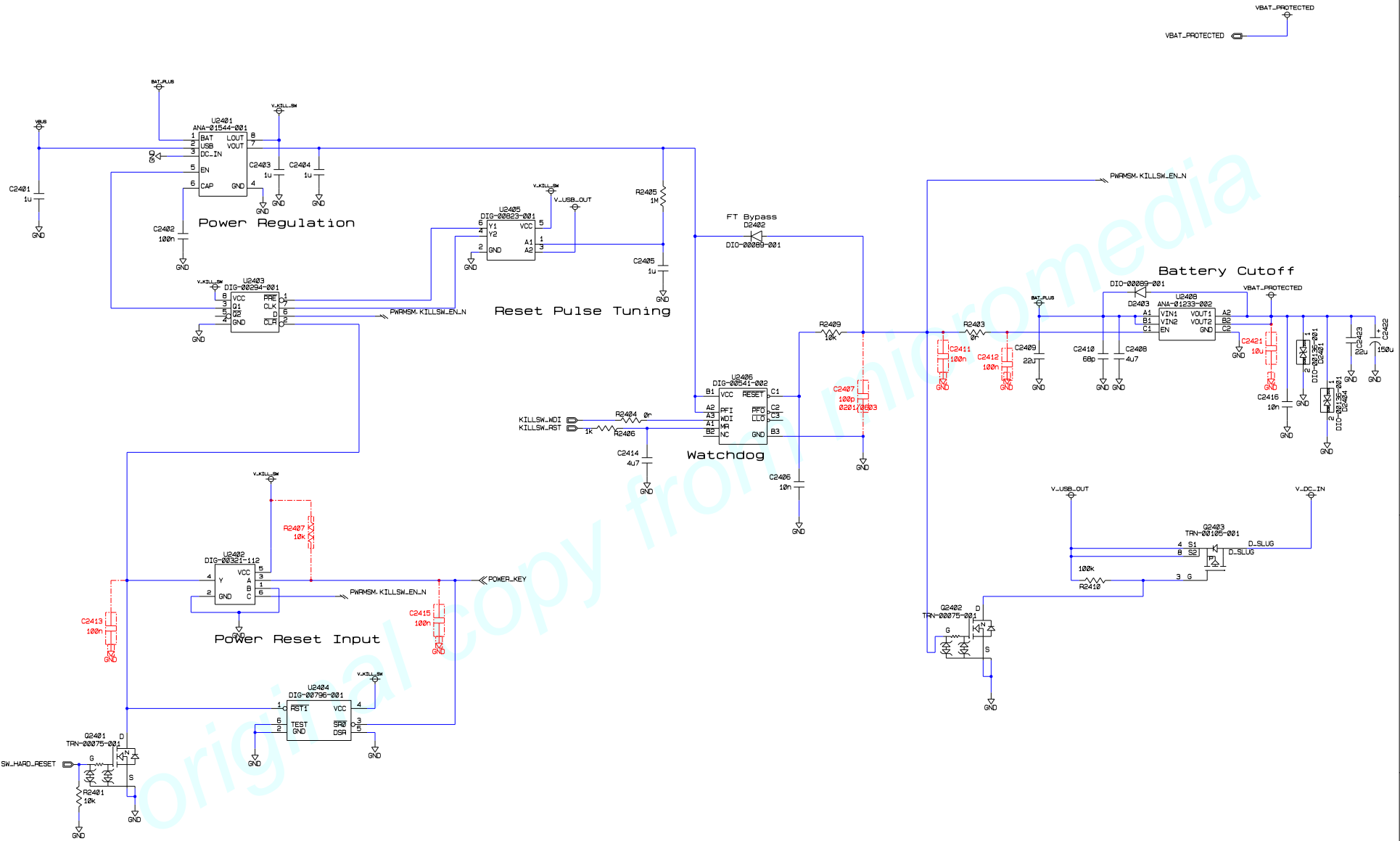

RESEARCH IN MOTION CONFIDENTIAL

HIERARCHICAL BLOCK POWER_MSM	COPYRIGHT 2012 RESEARCH IN MOTION LIMITED 295 PHILLIP ST. WATERLOO, ONTARIO CANADA
DRAWN BY A. Shafique	PHONE (519) 888-7465 FAX (519) 888-6986
R&D CHECK Ottawa CDMA Team	TITLE R069 VERIZON
MFG CHECK mfqch	uses PCB-44884-010
EDITED BY: ashafique	SIZE DRAWING No. SCH-44885-010
LAST EDIT: 2013/01/08 08:29:09	REV 2 SHEET 24 of 34

D

C

D

C

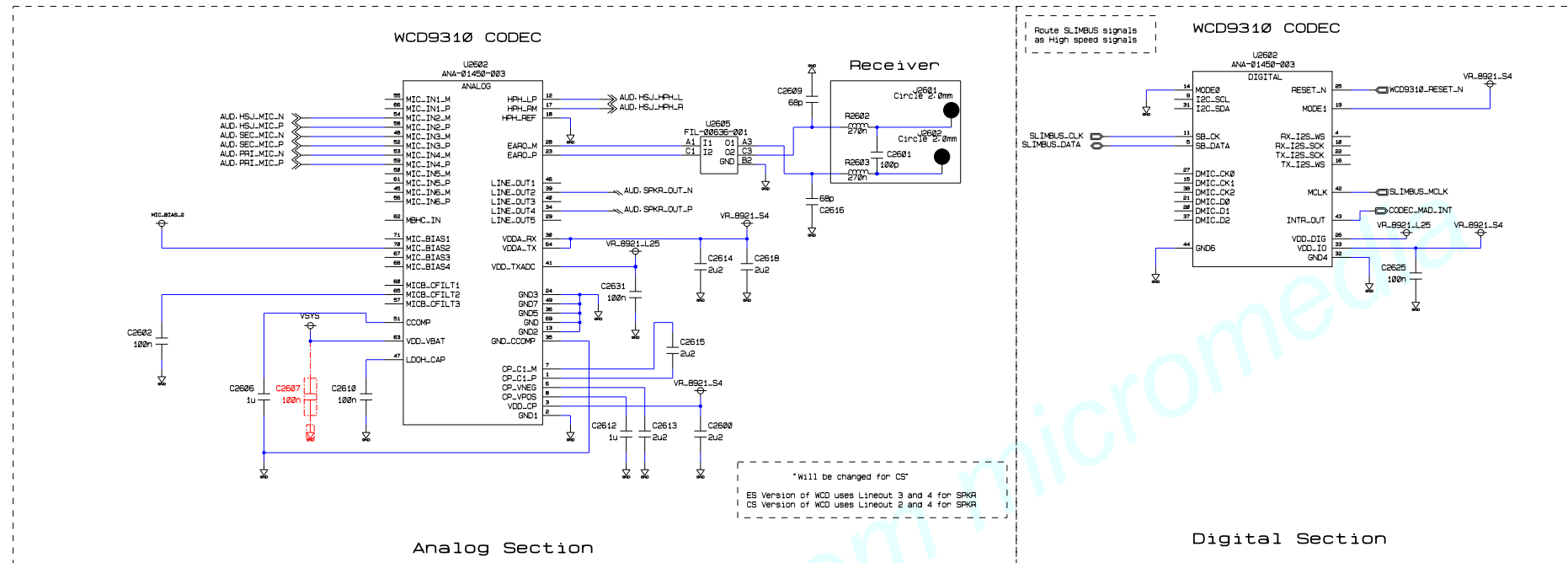

B

A

B

A

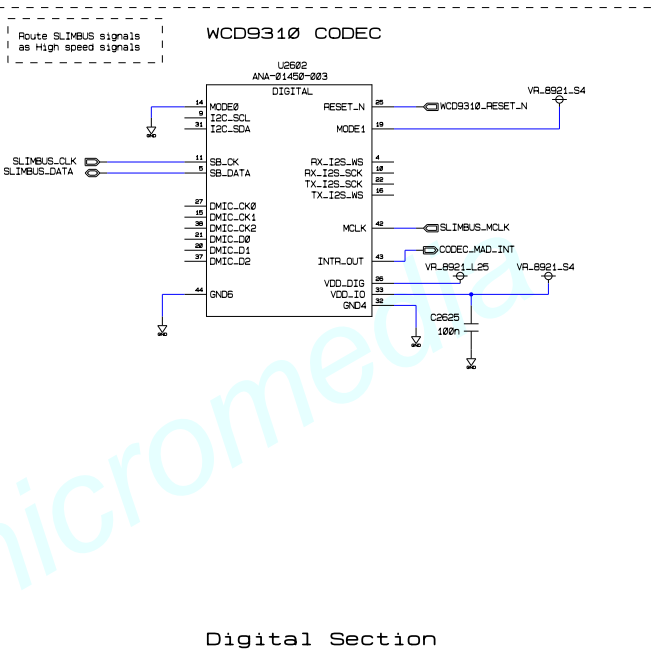
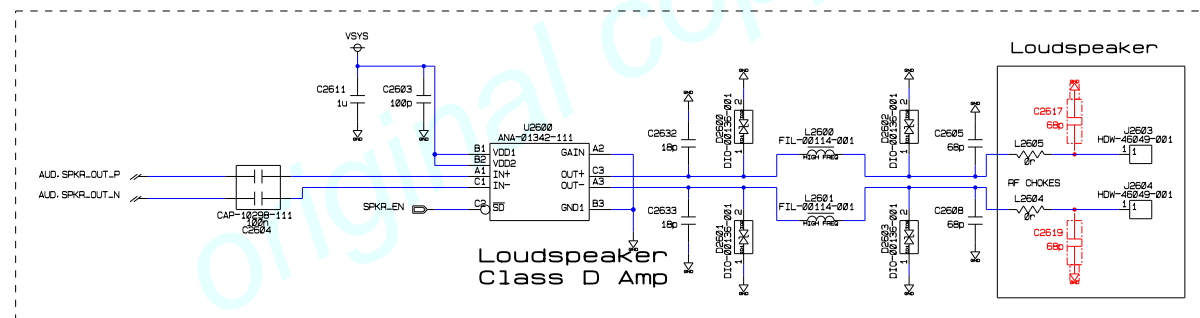

Digital Section

Analog Section

RESEARCH IN MOTION CONFIDENTIAL

HIERARCHICAL BLOCK AUDIO	COPYRIGHT 2012 RESEARCH IN MOTION LIMITED 295 PHILIP ST. WATERLOO, ONTARIO CANADA
DRAWN BY A. Shafique	PHONE (519) 888-7465 FAX (519) 888-6986
R&D CHECK Ottawa CDMA Team	TITLE R069 VERIZON
MFG CHECK mfqch	uses PCB-44884-010
EDITED BY: ashafique	SIZE DRAWING No. SCH-44885-010
LAST EDIT: 2013/01/08 08:29:08	REV 2 SHEET 26 of 34

4

3

2

1



D

D

C

C

B

B

A

A

Page Intentionally Left Blank

original copy from micromedia

RESEARCH IN MOTION CONFIDENTIAL

HIERARCHICAL BLOCK ALDIO	COPYRIGHT 2012 RESEARCH IN MOTION LIMITED 295 PHILIP ST. WATERLOO ONTARIO CANADA	
DRAWN BY: A. Shafique	PHONE (519) 888-7465 FAX (519) 888-6986	
R&D CHECK: Ottawa CDMA Team	TITLE R069 VERIZON	
MFG CHECK: mfgch	uses PCB-44884-010	
EDITED BY: mkapadja	SIZE C	DRAWING No. SCH-44885-010
LAST EDIT: 2013/01/08 08:29:08	REV 2	SHEET 27 of 34

4

3

2

1



DISPLAY AND TOUCHSCREEN

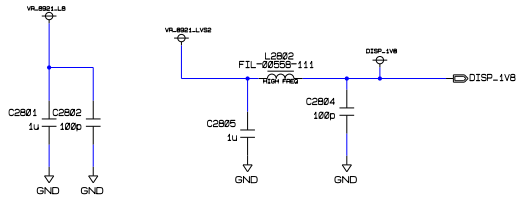
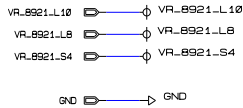

LCD Connector

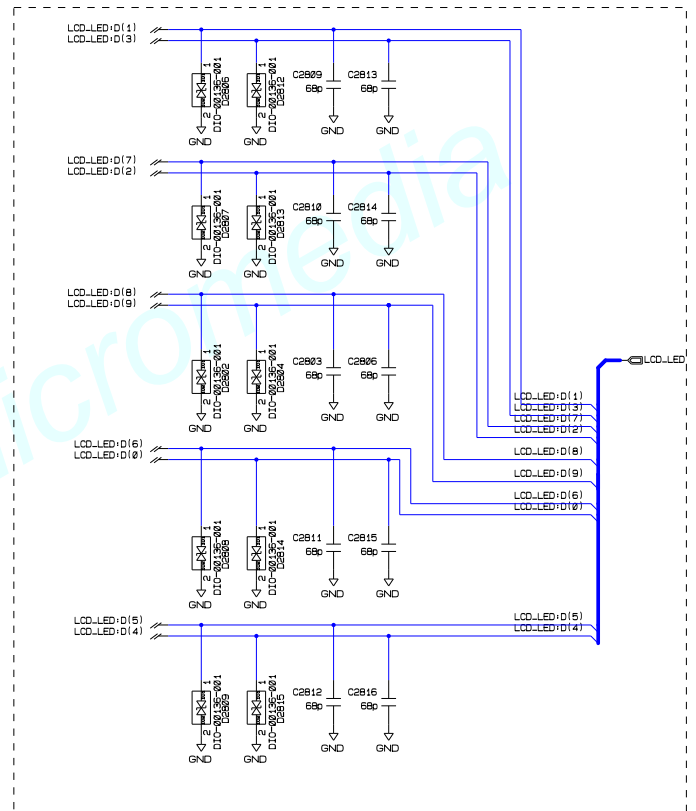
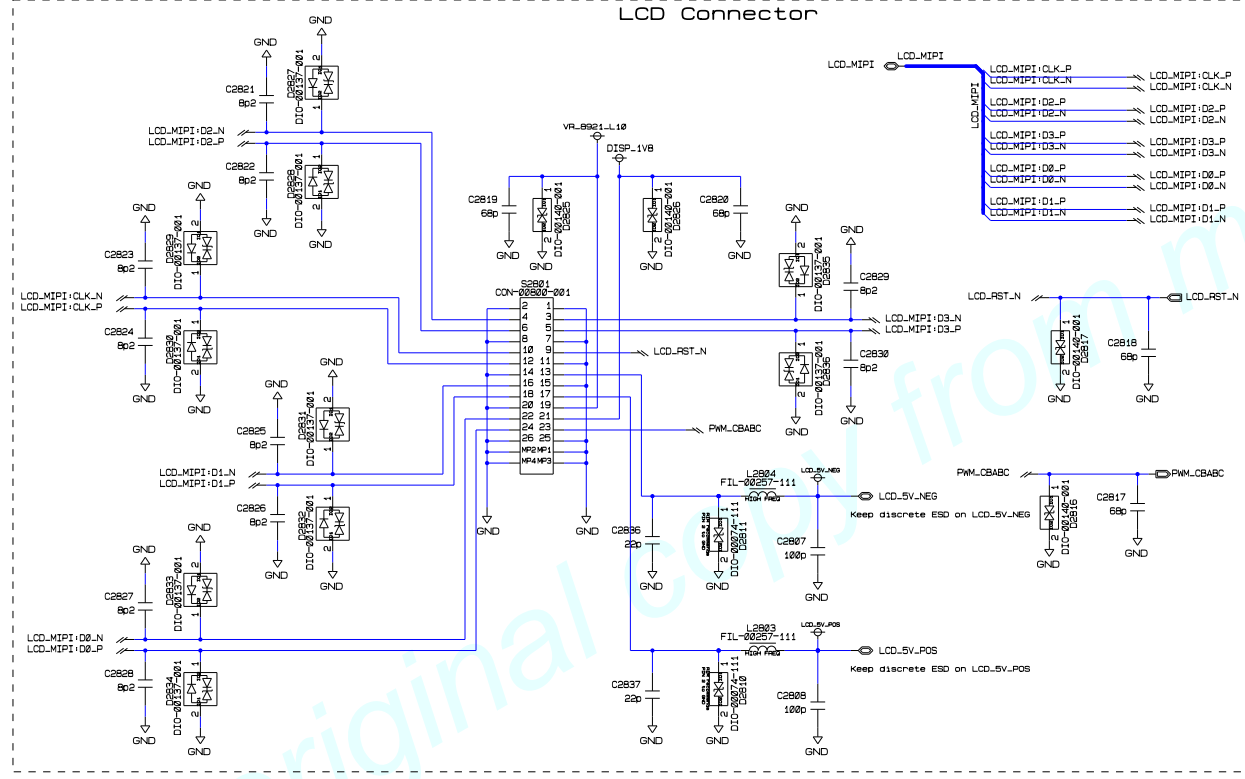

LED Connector

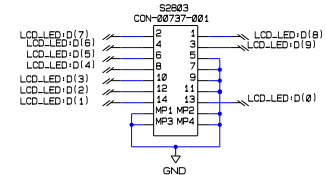

Touchscreen Connector

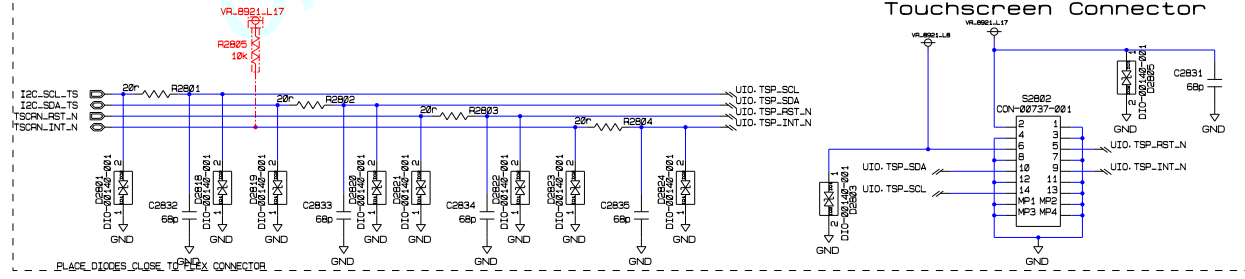

RESEARCH IN MOTION CONFIDENTIAL		
HIERARCHICAL BLOCK USER_10	COPYRIGHT 2012 RESEARCH IN MOTION LIMITED 295 PHILIP ST. WATERLOO, ONTARIO CANADA	
DRAWN BY A. Sharifque	PHONE (519) 886-7465 FAX (519) 886-6926	
RND CHECK Ottawa CDMA Team	TITLE R069 VERIZON uses PCB-44884-010	
MFG CHECK mfgcn	SIZE DRAWING No. SCH-44885-010	
EDITED BY: mkapadia	LAST EDIT: 2012/09/06 11:10:02	
REV 2	SHEET 28	OF 34

D

D

C

C

B

B

A

A

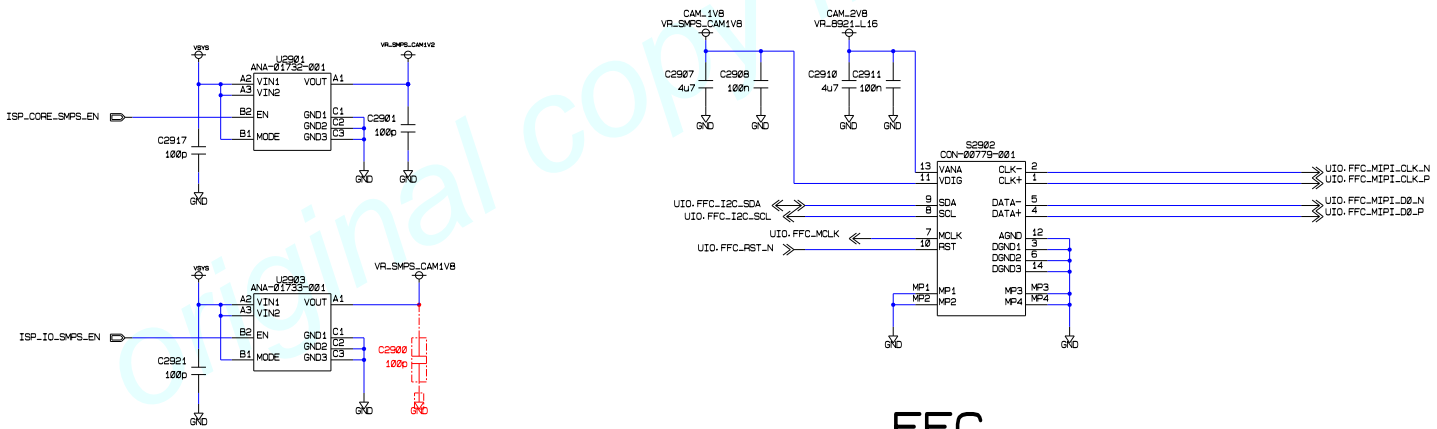
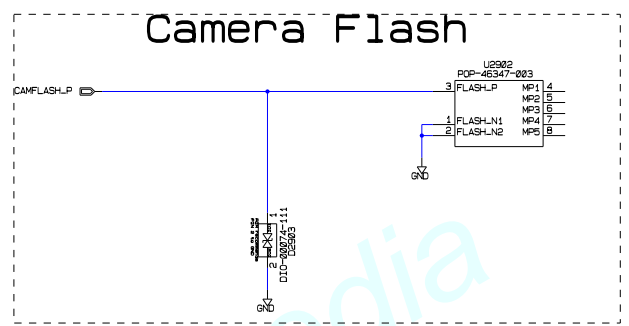
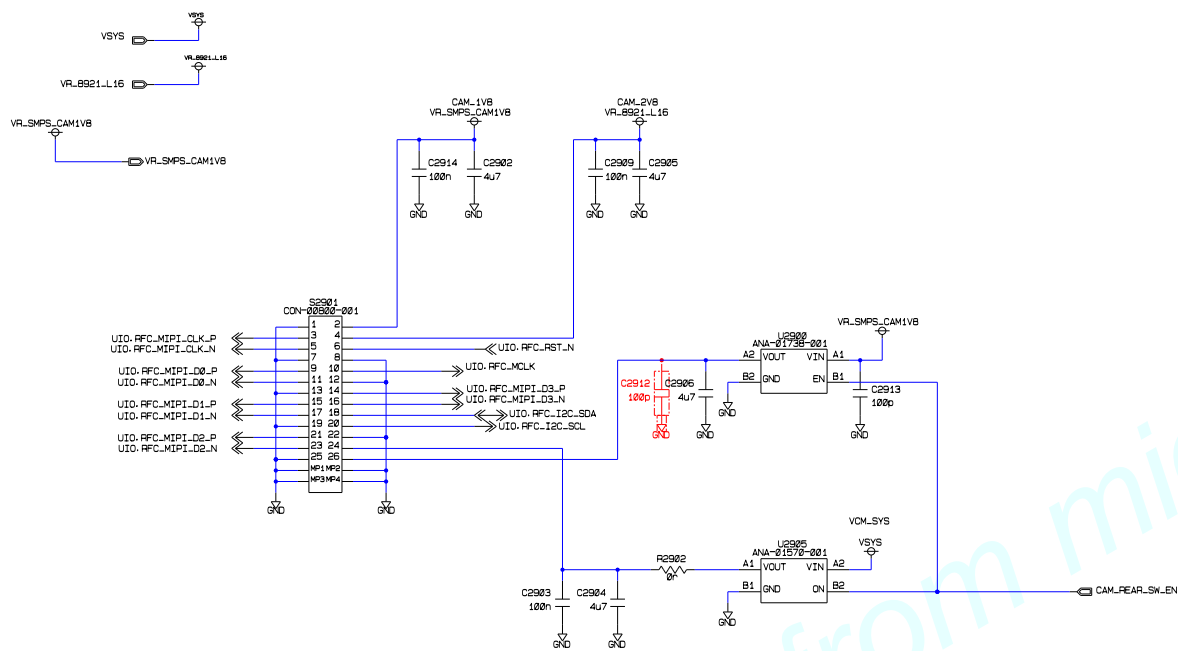

FFC

RESEARCH IN MOTION CONFIDENTIAL

HIERARCHICAL BLOCK USER_IO	COPYRIGHT 2012 RESEARCH IN MOTION LIMITED 295 PHILIP ST. WATERLOO, ONTARIO CANADA PHONE (519) 888-7465 FAX (519) 888-6906
DRAWN BY A. Shafique	TITLE R069 VERIZON uses PCB-44884-010
RND CHECK Ottawa CDMA Team	SIZE DRAWING NO. SCH-44885-010
MFG CHECK mfgcn	REV 2 SHEET 29 of 34
EDITED BY ashafique	
LAST EDIT: 2013/01/08 09:29:08	

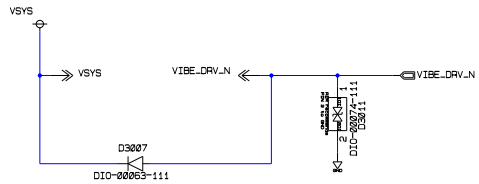

VIBRATOR

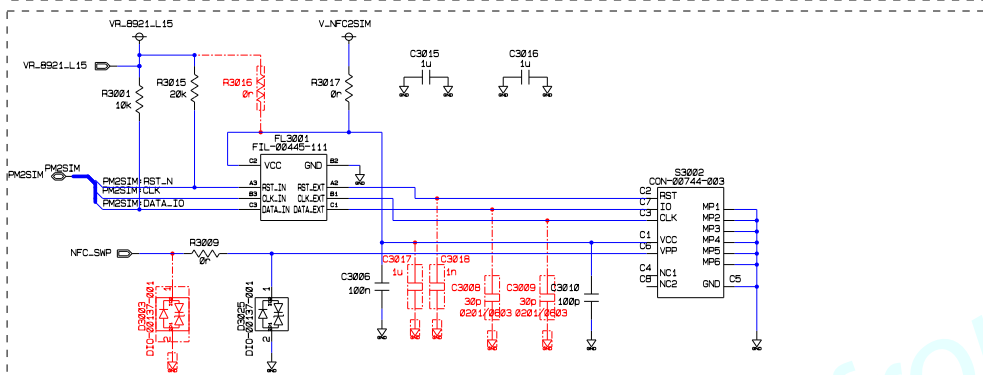

microSIM

IR, HEADSET, PWR Key TOP Flex

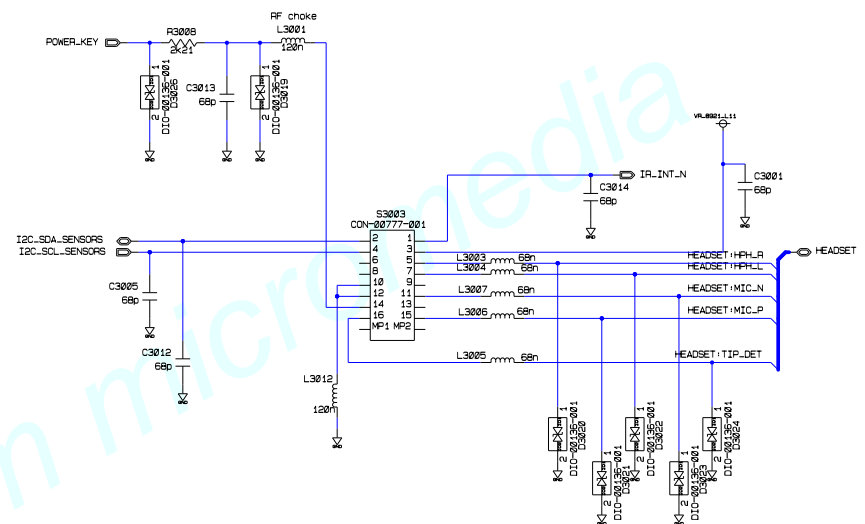

Populating the Capacitor C3007 or changing the 0Ohm series resistor R1925 on the USD CLK is to be avoided, and can only be done in collaboration with the memory team

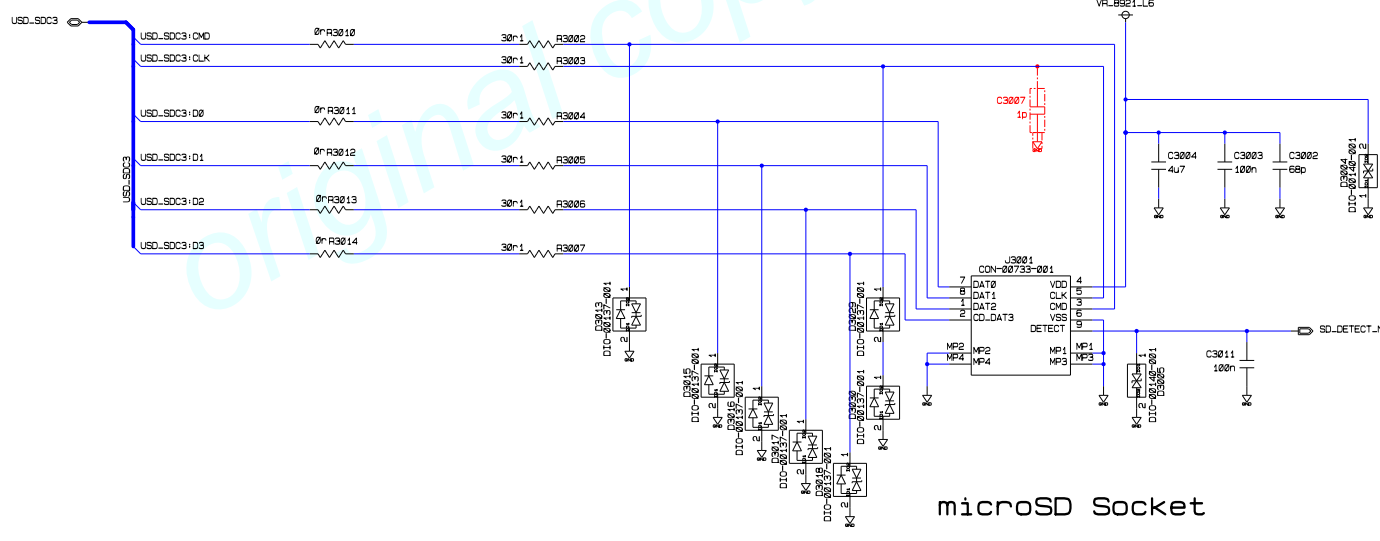

microSD Socket

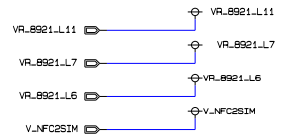

RESEARCH IN MOTION CONFIDENTIAL	
HIERARCHICAL BLOCK USER_IO	COPYRIGHT 2012 RESEARCH IN MOTION LIMITED 295 PHILIP ST. WATERLOO, ONTARIO CANADA
DRAWN BY A. Shafique	PHONE (519) 886-7465. FAX (519) 886-6906
R&D CHECK Ottawa CDMA Team	TITLE R069 VERIZON uses PCB-44884-010
MFG CHECK Infogch	SIZE DRAWING NO. SCH-44885-010
EDITED BY ashafique	LAST EDIT: 2013/01/08 09:29:08
LAST EDIT: 2013/01/08 09:29:08	SHEET 30 of 34

HDMI Connector

Side Key, RGB, AND Vibrator Flex

D

D

C

C

B

B

A

A

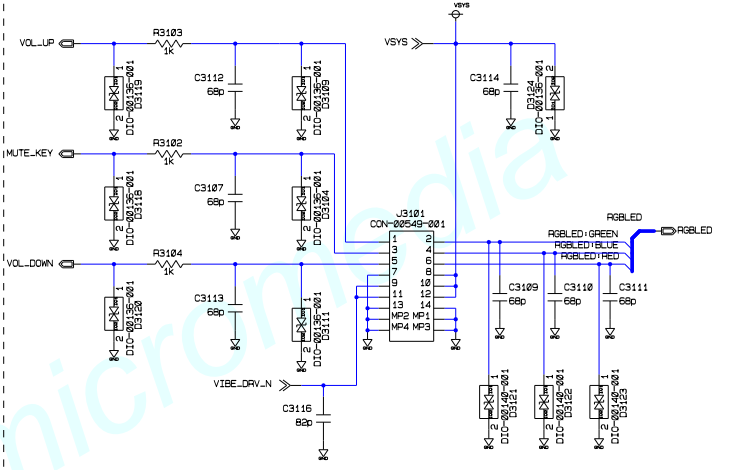
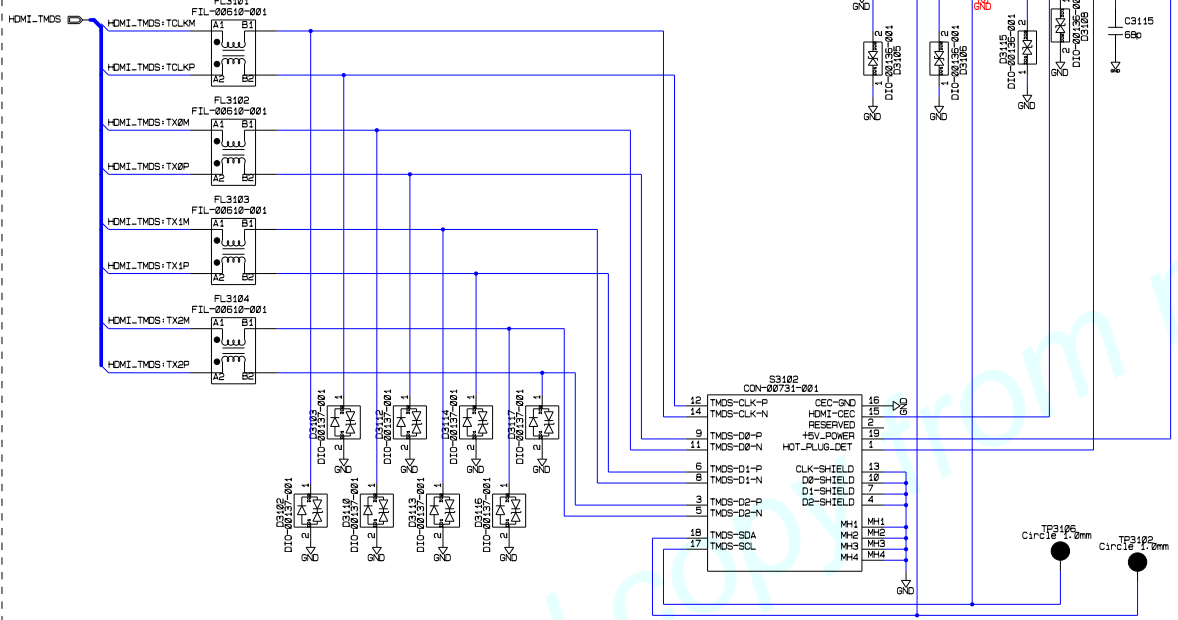

USB Connector

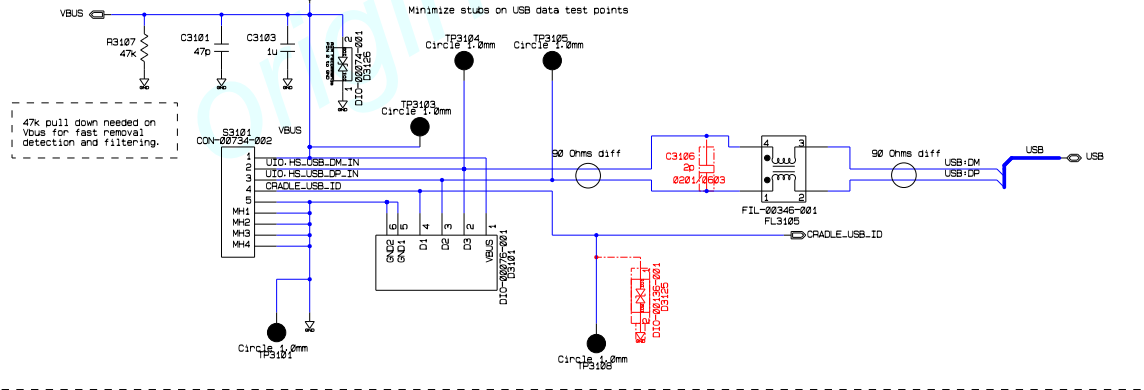

RESEARCH IN MOTION CONFIDENTIAL		
HIERARCHICAL BLOCK USER_IO	COPYRIGHT 2012 RESEARCH IN MOTION LIMITED 295 PHILIP ST. WATERLOO, ONTARIO CANADA	
DRAWN BY A. Shafiqe	PHONE (519) 886-7465- FAX (519) 886-6906	
RND CHECK Ottawa CDMA Team	TITLE R069 VERIZON	
MFG CHECK mfgcn	uses PCB-44884-010	
EDITED BY: ashafiqe	SIZE C	DRAWING NO. SCH-44885-010
LAST EDIT: 2013/01/08 09:29:09	REV 2	SHEET 31 of 34

Accelerometer

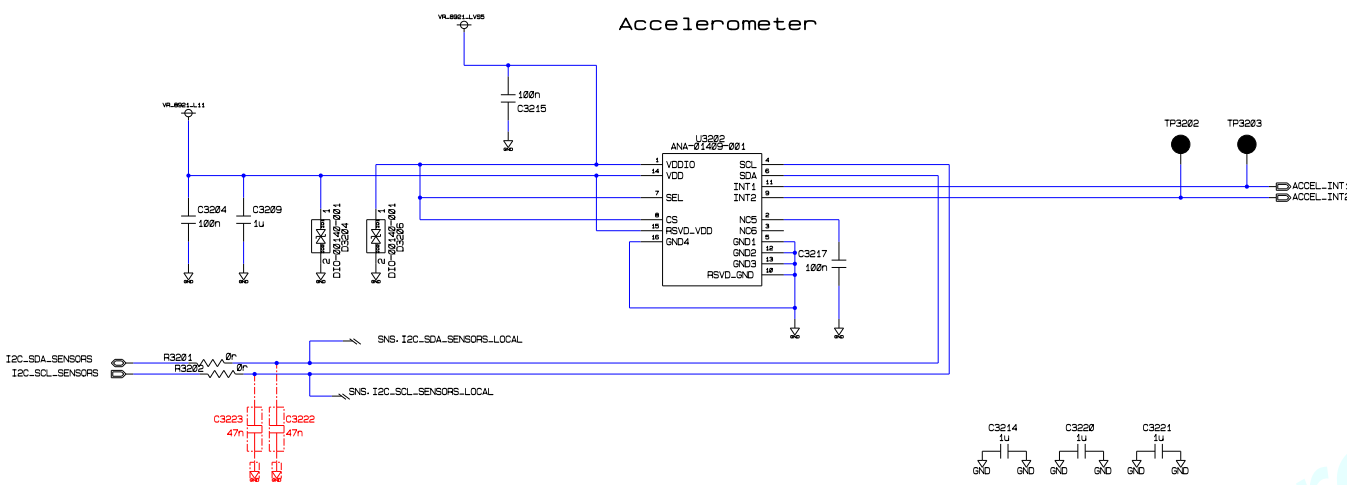

** See Sensor DFM - DFM-MEMS-DR-01 for Layout Guidelines **

Magnetometer

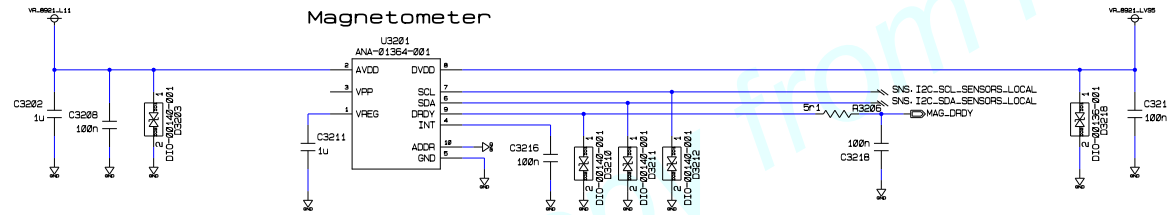

Magnetometer
 ANA-01364-001 AM2306R I2C Address 0x1C (8-bit)
 ANA-01312-001 AM2310 I2C Address 0x1D (8-bit)
 ** See Sensor DFM - DFM-MEMS-DR-01 for Layout Guidelines **
 ** Common Magnetometer RIM PN TBC **

Gyroscope

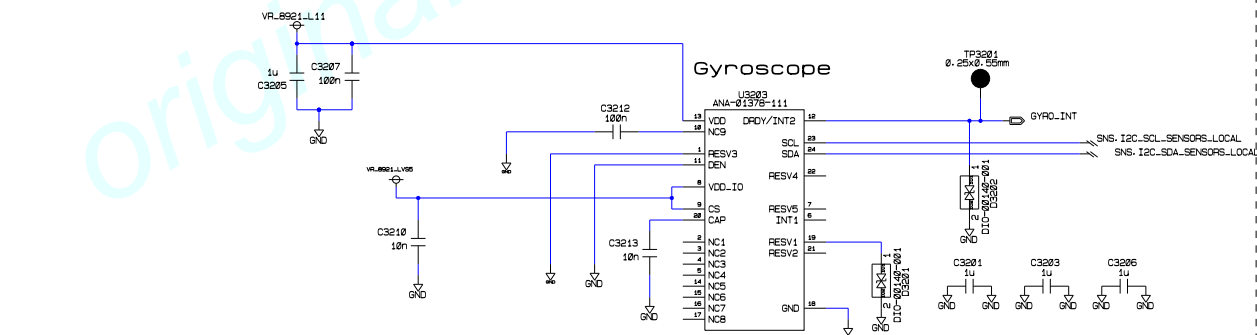

Gyroscope: Notes:
 ANA-01379-001 ST Micro R3G020 (FCS 2011), I2C address 0xD4 (8-bit)
 ANA-01051-001 InvenSense MPU-3050 (FCS 1H 2011), I2C address 0xD2 (8-bit)
 ANA-01379-001 InvenSense MPU-6050 (FCS 2H 2011), I2C address 0xD2 (8-bit)
 ** Common Gyroscope RIM PN TBC **

** Sns resonator start-up time increase for MPU-3050 with C3512*10*F **
 ** Pins 2,3,4,5,14,15,16,17 can be tied to GND and used for achieving routing symmetry and SMT self-alignment **
 ** See Sensor DFM - DFM-MEMS-DR-01 for Layout Guidelines **

RESEARCH IN MOTION CONFIDENTIAL	
HIERARCHICAL BLOCK SENSORS	COPYRIGHT 2012 RESEARCH IN MOTION LIMITED 295 PHILIP ST. WATERLOO, ONTARIO CANADA
DRAWN BY A. Shafiqe	PHONE (519) 886-7465- FAX (519) 886-6926
R&D CHECK Ottawa CDMA Team	TITLE R069 VERIZON
MFG CHECK Infgn	uses PCB-44884-010
EDITED BY Aautho	SIZE DRAWING NO. SCH-44885-010
LAST EDIT: 2013/01/08 09:29:09	REV 2 SHEET 32 of 34

D

D

C

C

B

B

A

A

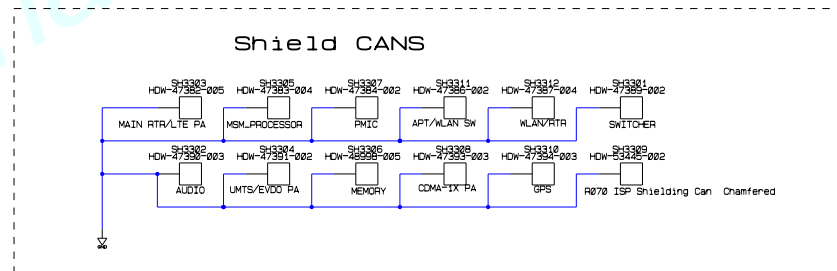
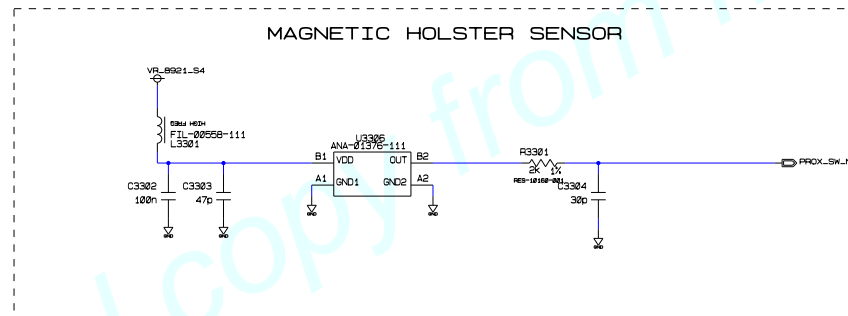
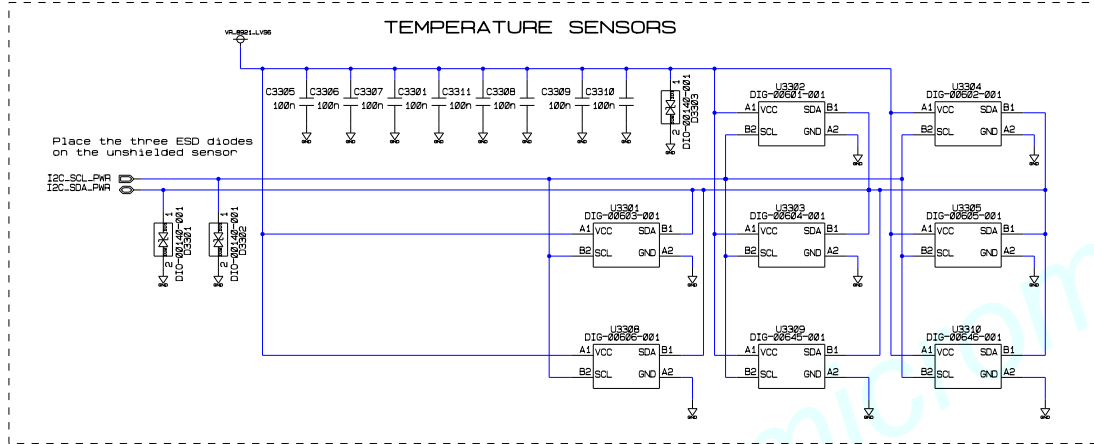
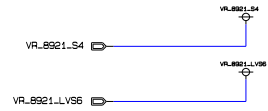

RESEARCH IN MOTION CONFIDENTIAL

HIERARCHICAL BLOCK SENSORS	COPYRIGHT 2012 RESEARCH IN MOTION LIMITED 295 PHILIP ST. WATERLOO, ONTARIO CANADA
DRAWN BY A. Shafique	PHONE (519) 888-7465- FAX (519) 888-6906
R&D CHECK Ottawa CDMA Team	TITLE R069 VERIZON
MFG CHECK Infgn	uses PCB-44884-010
EDITED BY: ashaf1que	SIZE DRAWING NO. SCH-44885-010
LAST EDIT: 2013/01/08 09:29:09	REV 2 SHEET 33 of 34

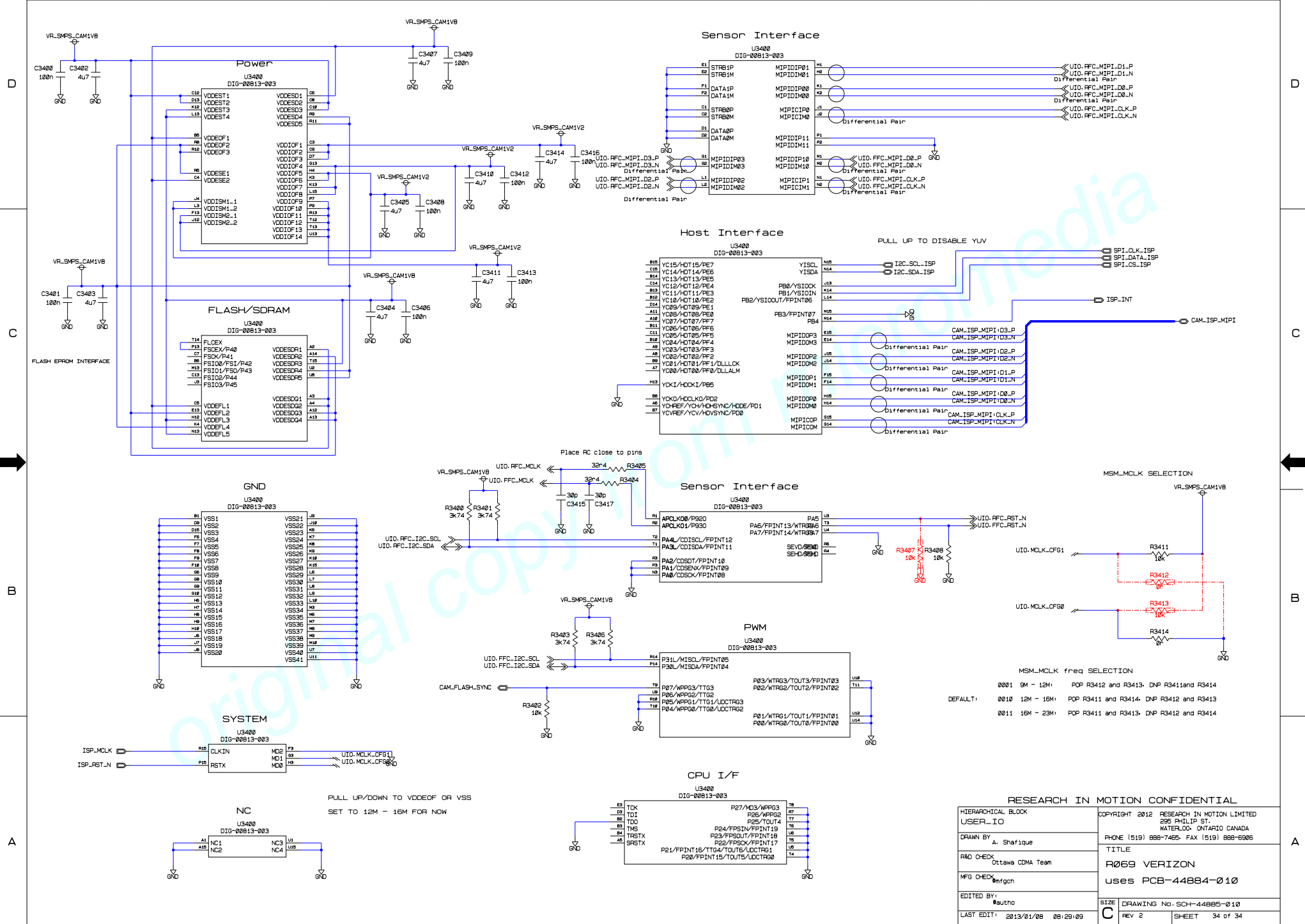

MSM_MCLK freq SELECTION

0001	9M - 12M	POP R3412 and R3413. DNP R3411 and R3414
0010	12M - 16M	POP R3411 and R3414. DNP R3412 and R3413
0011	16M - 23M	POP R3411 and R3413. DNP R3412 and R3414

DEFAULT: 0010

RESEARCH IN MOTION CONFIDENTIAL

HIERARCHICAL BLOCK USER_IO	COPYRIGHT 2012 RESEARCH IN MOTION LIMITED 295 PHILIP ST. WATERLOO, ONTARIO CANADA
DRAWN BY A. Shafique	PHONE (519) 888-7465. FAX (519) 888-6986
RWD CHECK Ottawa CDMA Team	TITLE R069 VERIZON
MFG CHECK mfqch	uses PCB-44884-010
EDITED BY aautho	SIZE DRAWING No. SCH-44885-010
LAST EDIT: 2013/01/08 08:29:09	REV 2 SHEET 34 of 34